

WE SAY:
THE INNER VALUES
COUNT!



BETTER HEATING. SAFE BET.

TECHNICAL MANUAL DIAPHRAGM EXPANSION VESSELS

Ver.01/2022-en

Table of contents

1. General	3
1.1 Operating principle and construction	3
1.2 The meaning of the gas pressure	3
1.3 Application	4
2. Product overview	4
3. Sizing	5
3.1 Safety expansion vessels for heating, climatic and cold water systems	5
3.2 Expansion vessels for warm water sanitary systems	12
3.3 Safety expansion vessels for refrigeration systems	13
3.4 Safety expansion vessels for solar systems	18
3.5 Sizing with online design programme elko-online	22
3.6 Formulary	23
3.7 Tables	24
4. Technical data	27
4.1 Safety expansion vessels for heating, climatic and cold water systems	27
4.2 Universal vessels for heating, climatic and cold water systems	32
4.3 Expansion vessels for warm water sanitary systems	34
4.4 Expansion vessels for cold water sanitary systems	35
4.5 Safety expansion vessels for refrigeration systems	36
4.6 Safety expansion vessels for solar systems	37
5. Accessory	38
5.1 elko-flex eder maintenance unit	38
5.2 elko-mat eder EV cooling vessel	38
5.3 elko-mat eder SV safety valve	39

Information to standards

Mentioned and quoted standards refer to the following versions:

- EN 12828:2013-01-01 Heating systems in buildings - Design for water-based heating systems
- ÖNORM H 5151-1:2010-12-15 Planung von zentralen Warmwasser-Heizungsanlagen mit oder ohne Warmwasserbereitung - Teil 1
- ÖNORM H 5155:2013-09-01 Wärmedämmung von Rohrleitungen und Komponenten in haustechnischen Anlagen
- ÖNORM M 7777-2:2013-09-01 Solarthermische Anlagen - Teil 2
- EN ISO 4126-1:2013-10-15 Safety devices for protection against excessive pressure - Part 1: Safety valves

Disclaimer

We improve our products permanently and so we reserve the right to make modifications anytime and without previous announcements. We assume no warranty for correctness or completeness of the present document. Any claims, particularly claims for damages and loss of profit or financial losses must be excluded!

1. General

1.1 Operating principle and construction

Sealed diaphragm expansion vessels are safety devices for systems which use a liquid heat transfer medium - primarily water - to transport heat resp. cold to the particular loads.

A diaphragm expansion vessel consists of 2 chambers, which are divided by a high-quality membrane. In EDER expansion vessels this membrane is designed as a bag and encloses the medium completely. There is no contact between the medium and the metal wall of the vessel, thus corrosion is avoided.

The water chamber stores the change in water volume due to heating up. In case of cooling down the pressure inside the gas chamber presses the medium back to the system.

figure: expansion vessel in operation

Minimum system temperature

The expansion vessel contains a water reserve.

The system temperature rises

The expansion vessel accommodates the incurring expansion volume inside the membrane.

Maximum system temperature

The expansion vessel stores the expansion volume completely

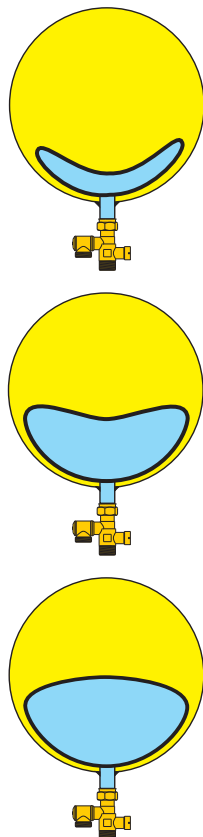

1.2 The meaning of the gas pressure

A missing resp. incorrect set gas pressure affects the complete operation of the entire system.

Therefore a individual inspection and adjustment of the gas pressure must be done prior to commissioning resp. once a year.

As mentioned above, the gas pressure shall ensure that the expansion volume is pressed back to the system in case of cooling down. Also it protects the vessel from overfilling.

If the gas pressure is missing or too small, the expansion vessel accommodates too much water at low system temperatures. In case of heating up, there is no room left for the physical expansion. Furthermore the durability of the expansion vessel is affected due to over-use of the membrane.

If the gas pressure is too high, the capacity of the vessel is reduced and the function of the system is disturbed too.

Due to the fact that the pressure in both chambers is equal, the expansion vessel must be pressure relieved when checking the gas pressure.

To check the gas pressure without draining the system, special armatures, so-called maintenance units, are available.

The gas pressure can be checked with a conventional tire-pressure gauge.

The necessary pressure within the gas chamber depends on the static height above the connection point of the expansion vessel.

If the temperature is above 100°C, the gas pressure must be increased by the value of the vapour pressure.

In this case the membrane must be protected from excessive temperature too.

After adjusting the gas pressure to the plant, the system can be filled to the adequate system pressure.

The detailed sizing procedure is described in Section 3.

figure: effect of the gas pressure

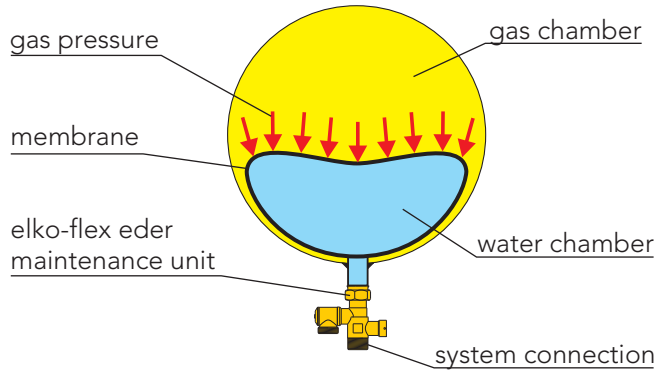

1.3 Application

The main applications of diaphragm expansion vessels are

- central heating systems
- climatic and cold water systems
- solar systems
- drinking and service water systems
- water hammer arrestors
- etc.

2. Product overview

heating, climatic and cold water systems

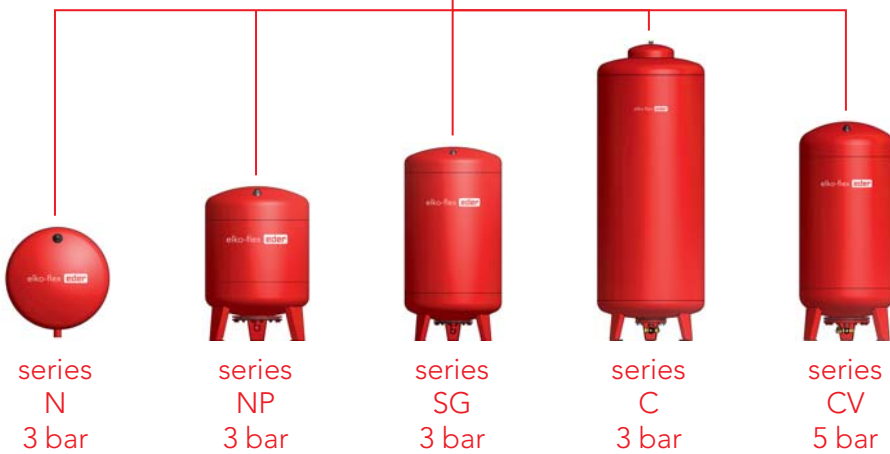

heating, solar, cold water



sanitary systems

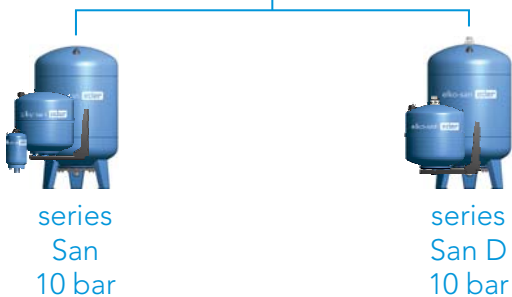

refrigeration systems



solar systems



3. Sizing

The Sizing of expansion vessels is made according to relevant standards, for example EN 12828. A too small resp. incorrect sized expansion vessel affects the function of the system just as a incorrect set gas pressure.

If the expansion vessel is too small, it is unable to store the entire expansion volume.

In case of heating up, a part of the expansion volume gets lost via the system safety valve.

When cooling down, this volume is missing and the

pressure falls below its minimum value. Negative pressure arises and the system sucks air via various components (stuffing boxes, air vents etc.). Corrosion and circulation problems are the consequences.

To ensure a proper function, special attention must be paid to the correct sizing of the expansion vessel.

3.1 Safety expansion vessels for heating, climatic and cold water systems

3.1.1 hydraulic connection

example: elko-flex eder safety expansion vessel in hanging position

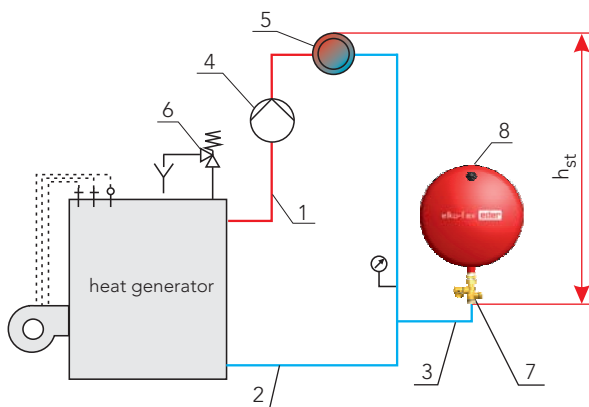

- 1 ... heating flow
- 2 ... heating return
- 3 ... expansion pipe
- 4 ... circulation pump
- 5 ... load
- 6 ... system safety valve
- 7 ... elko-flex eder maintenance unit
- 8 ... elko-flex eder safety expansion vessel
- h_{st} ... static height

elko-flex eder safety expansion vessels for sealed systems are sized according to the standard EN 12828 „Heating systems in buildings“.

A correct and sufficient sizing ensures a trouble-free operation of the system.

elko-flex eder safety expansion vessels store the temperature-dependent changes in water volume in sealed heating, climate and cold water systems with a maximum operating pressure of 3, 5, 6 resp. 10 bar and a maximum operating temperature of 90 °C (max. long-term temperature of the vessel is 70 °C). If the max. operating temperature is higher (max. 110 °C), an EV cooling

vessel (compare „accessory“) must be installed. This cooling vessel ensures an adequate cooling of the expansion volume before it gets into the expansion vessel.

According to ÖNORM H 5151-1 the use of more than one diaphragm expansion vessels must be avoided.

The recommended connection point of the safety expansion vessel is the (pressure-)neutral point in the pipe system. At this point the static resp. the final pressure is constant, independent from the operation of the circulation pumps.

The position of the integration point should be

chosen in such a way that the pressure on the suction side of the circulation pump is sufficient for operation, e.g. avoiding cavitation, and high temperatures affecting the diaphragm of the expansion vessel.

3.1.2 Sizing of diaphragm expansion vessels according to EN 12828*:

* In Austria the standard ÖNORM H 5151-1 may also be applied as a supplement to EN 12828.

The size of the diaphragm expansion vessel depends on:

- the total content of the system V_{System}
- the static height h_{st}
- the final pressure p_{fin}
- the density ρ of the used medium, depending on the lowest and the maximum set operation temperature

Calculation of the **gas pressure (minimum operating pressure) p_0** in the System:

$$p_0 = p_{st} + 0,2 + p_v$$

- ϑ_{min} lowest system temperature
- ϑ_{max} maximum set operating temperature (flow temperature of the heat generator)
- p_{sv} set pressure of the safety valve
- p_{PAZ} pressure at which the pressure limiter operates.
- p_{fin} final pressure
- p_{fil} filling pressure - required pressure in the system if the lowest possible temperature is not given. (for filling of make-up)
- p_0 gas pressure (=minimum operating pressure, effectively avoiding evaporation, cavitation, vacuum)
In addition the minimum pressure requirements of other system components need to be taken into consideration. An addition of at least 0,2 bar to the static height is recommended.

illustration of the different pressure levels:

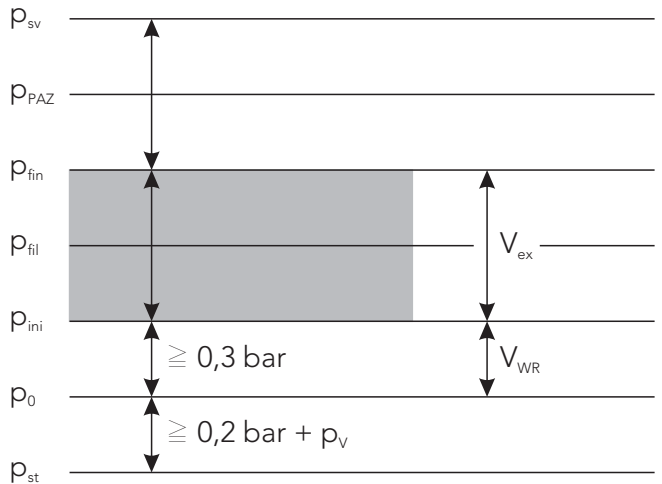

- p_{ini} initial pressure
- p_{st} static height pressure - pressure only resulting from the difference in height h_{st} between the position of the pressurization system and the highest point of the heating system.
10 meter water column (mWs) ~ 1 bar
- p_v vapour pressure at safety temperature (lockout set point temperature of the safety temperature lockout device)
Generally, specific values for the vapour pressure are values for pure water without any antifreeze additives (see table 3)
- V_{ex} expansion volume
- V_{WR} real water reserve volume in the pressure vessel used.

operating band of the pressurization system

calculation example:

(sealed heating system with $\vartheta_{\max} = 95^\circ\text{C}$)

The water column above the expansion vessel is 7m. How large does the gas pressure p_0 have to be?

solution:

given: $h_{\text{st}} = 7 \text{ mWs} \rightarrow p_{\text{st}} = 0,7 \text{ bar}$

$p_v = 0 \text{ bar}$

asked for: p_0

$$p_0 = p_{\text{st}} + 0,2 + p_v = 0,7 + 0,2 + 0 = \underline{0,9 \text{ bar}}$$

The gas pressure p_0 within the vessel must be 0,9 bar.

Later the **total content of the system** V_{System} must be determined. It is the total content of the pipework, heat emitters, heat generators and connected auxiliary circuits. Where it is not feasible to make an accurate calculation, extra care should be taken in estimating the volume.

If the volumes of the individual components are unknown, the volume of the system can be determined approximately by using the nominal power of the heat generator and the plant-specific water content f_{an} (table 1).

$$V_{\text{System}} = f_{\text{an}} \times \Phi_{\text{NL}}$$

Φ_{NL} max. power of the heat generator [kW]

f_{an} plant-specific water content [l/kW]
(table 1)

The **expansion volume** V_{ex} is the increase in volume caused by temperature increase between the lowest possible temperature of the heating system and the maximum set operating temperature of the heat generator.

V_{ex} is determined by using the expansion coefficient e :

$$V_{\text{ex}} = V_{\text{System}} \times e$$

$$e = 1 - \frac{\rho_{\vartheta_{\max}}}{\rho_{\vartheta_{\min}}}$$

$\rho_{\vartheta_{\max}}$ density of the medium at the maximum set operating temperature of the heat generator [kg/m³] (table 5)

$\rho_{\vartheta_{\min}}$ density of the medium at the lowest system temperature [kg/m³] (table 5)

Note: The density of water (table 5) will be affected by the density of additive substances (e.g. antifreeze additives).

Usually the lowest system temperature is equal to the filling temperature of 10°C.

Used additive substances can affect the material of the diaphragm!

calculation example:

How large is the expansion volume of a sealed heating system with convectors and a nominal power of $\Phi_{\text{NL}} = 30 \text{ kW}$?

solution:

given: $\Phi_{\text{NL}} = 30 \text{ kW}$

$f_{\text{an}} = 9 \text{ l/kW}$ (acc. to table 1)

$\vartheta_{\max} = 95^\circ\text{C}$

asked for: V_{ex}

$$V_{\text{System}} = f_{\text{an}} \times \Phi_{\text{NL}} = 9 \times 30 = 270 \text{ l}$$

$$e = 1 - \frac{\rho_{\vartheta_{\max}}}{\rho_{\vartheta_{\min}}} = 1 - \frac{961,7}{999,8} = 3,8 \%$$

$$V_{\text{ex}} = V_{\text{System}} \times e = 270 \times 3,8 \% = \underline{10,29 \text{ l}}$$

The expansion volume is 10,29 l.

In addition to the expansion volume, the expansion vessel should have a minimal water reserve.

The **water reserve** V_{WR} compensates possible water losses in the system. Expansion vessels with a nominal volume up to 15 l should accommodate at least 20 % of this volume as a water reserve. Expansion vessels with a nominal volume greater than 15 l should accommodate a water reserve of at least 0,5 % of the total content of the system, however, at least 3 l.

$$V_{WR} = \frac{V_N \times 20}{100} \quad \text{if } V_N \leq 15 \text{ l}$$

$$V_{WR} = \frac{V_{System} \times 0,5}{100} \geq 3 \quad \text{if } V_N > 15 \text{ l}$$

- V_{WR} water reserve [l]
- V_N nominal volume of the expansion vessel [l]
- V_{System} total content of the system [l]

calculation example:

How large does the water reserve V_{WR} have to be, if the total content of the heating system is 1.050 litres?

solution:

given: $V_{System} = 1.050$ litres
 asked for: V_{WR}

Note: Due to the total content of the system it can be assumed that the nominal volume of the expansion vessel is greater than 15 litres!

$$V_{WR} = \frac{V_{System} \times 0,5}{100} = \frac{1.050 \times 0,5}{100} = \underline{5,25 \text{ l}}$$

The water reserve V_{WR} is 5,25 litres.

The **final pressure** p_{fin} indicates the highest pressure in the operating range of the heating

system. It should not be higher than the set pressure of the safety valve minus a difference in shut-off overpressure, the so-called closing pressure difference p_{SD} .

According to EN ISO 4216-1 a closing pressure difference of 20 %, at least 0,6 bar is admissible.

$$p_{SD} = p_{SV} \times 20 \% \geq 0,6 \text{ bar}$$

$$p_{fin} = p_{SV} - p_{SD}$$

- p_{SD} closing pressure difference [bar]
- p_{SV} set pressure of the safety valve [bar]
- p_{fin} final pressure [bar]

Note: The standard ÖNORM H 5151-1 specifies the closing pressure difference p_{SD} with 10 % of the set pressure (blow-off pressure) P_{SV} of the safety valve, at least 0,5 bar.

Usually in Austria the **minimum set pressure of the safety valve** p_{sv} is defined with 2 bar above the static pressure p_{st} , at least 3 bar!

$$p_{SV} = p_{st} + 2 + p_v \geq 3 \text{ bar}$$

calculation example:

How large is the final pressure p_{fin} in a sealed heating system with a static height of 7 m?

solution:

given: $h_{st} = 7 \text{ mWs} \rightarrow p_{st} = 0,7 \text{ bar}$
 asked for: p_{fin}

$$p_{SV} = p_{st} + 2 = 0,7 + 2 = 2,7 \text{ bar}$$

The minimum value is 3 bar $\rightarrow p_{SV} = 3 \text{ bar}$

$$p_{fin} = p_{SV} - p_{SD} = 3 - 0,6 = \underline{2,4 \text{ bar}}$$

The final pressure p_{fin} is 2,4 bar.

Calculation of the **minimum nominal volume** $V_{N,min}$ of diaphragm expansion vessels:

$$V_{N,min} = (V_{ex} + V_{WR}) \times \frac{p_{fin} + 1}{p_{fin} - p_0}$$

- $V_{N,min}$ minimum nominal volume [l]
- V_{ex} expansion volume [l]
- V_{WR} water reserve [l]
- p_{fin} final pressure [bar]
- p_0 gas pressure [bar]

calculation example:

Calculate the necessary nominal volume $V_{N,min}$ and the gas pressure p_0 for a diaphragm expansion vessel in a system with a total content of $V_{System} = 320$ l and a static height of $h_{st} = 8$ mWs. The maximum operating temperature is $\vartheta_{max} = 95$ °C.

solution:

- given: $V_{System} = 320$ litres
- $h_{st} = 8$ mWs $\rightarrow p_{st} = 0,8$ bar
- $\vartheta_{max} = 95$ °C
- asked for: $V_{N,min}$
- p_0

determination of the gas pressure p_0 :
 $p_0 = p_{st} + 0,2 + p_v = 0,8 + 0,2 + 0 = \underline{1}$ bar

determination of the set pressure p_{SV} :
 $p_{SV} = p_{st} + 2 = 0,8 + 2 = 2,8$ bar
The minimum value is 3 bar $\rightarrow p_{SV} = 3$ bar

determination of the final pressure p_{fin} :
 $p_{fin} = p_{SV} - p_{SD} = 3 - 0,6 = 2,4$ bar

determination of the expansion volume V_{ex} :

$$e = 1 - \frac{p_{\vartheta_{max}}}{p_{\vartheta_{min}}} = 1 - \frac{961,7}{999,7} = 3,8\%$$

$$V_{ex} = V_{System} \times e = 320 \times 3,8\% = 12,2$$
 l

determination of the water reserve V_{WR} :
Due to the total content of the system it can be assumed that the nominal content of the expansion vessel is greater than 15 litres.

$$V_{WR} = \frac{V_{System} \times 0,5}{100} = \frac{320 \times 0,5}{100} = 1,6$$
 l

The minimum value is 3 l $\rightarrow V_{WR} = 3$ l

determination of $V_{N,min}$:

$$V_{N,min} = (V_{ex} + V_{WR}) \times \frac{p_{fin} + 1}{p_{fin} - p_0}$$

$$V_{N,min} = (12,2 + 3) \times \frac{2,4 + 1}{2,4 - 1} = \underline{36,8}$$
 l

The required expansion vessel has to have a minimum nominal volume of 36,8 litres.

During commissioning the gas pressure must be set to 1,0 bar.

Selection and correct sizing of the diaphragm expansion vessel:

$$V_N \geq V_{N,min}$$

For diaphragm expansion vessels the initial pressure p_{ini} shall be confirmed for the selected vessel as follows:

$$p_{ini} = \frac{p_{fin} + 1}{1 + \frac{V_{ex}}{V_N} \times \frac{p_{fin} + 1}{p_0 + 1}} - 1$$

The correct sizing of the expansion vessel is ensured as long as:

$$p_{ini} \geq p_0 + 0,3 \text{ bar}$$

Otherwise the nominal volume V_N should be increased until the condition above is met.

calculation example:

Using the determined nominal volume, the expansion vessel can be selected from the tables in section "technical data".

It should be noted that the next larger expansion vessel must be selected!

solution:

given: $V_{N,min} = 36,8\text{ l}$

asked for: appropriate expansion vessel

→ selected vessel: elko-flex eder N 50

nominal volume V_N : 50 litres

max. operating pressure: 3 bar

max. long-term temperature: 70 °C

$$p_{ini} = \frac{p_{fil} + 1}{1 + \frac{V_{ex}}{V_N} \times \frac{p_{fil} + 1}{p_0 + 1}} - 1$$

$$p_{ini} = \frac{2,4 + 1}{1 + \frac{12,2}{50} \times \frac{2,4 + 1}{1 + 1}} - 1 = 1,41 \text{ bar}$$

$$p_{ini} \geq p_0 + 0,3 \text{ bar}$$

$$p_{ini} \geq 1 + 0,3 \text{ bar} = 1,3 \text{ bar}$$

The required term is fulfilled, the selected elko-flex eder N50 can be used.

Note: According to ÖNORM H 5151-1 a pump-controlled pressurization device is state of the art in larger systems (nominal power 100 kW and higher, total content 5000 litres and higher or 100 m² solar collector area).

The nominal volume $V_{N,min}$ of these expansion vessels is determined as follows (acc. to EN 12828):

$$V_{N,min} = (V_{ex} + V_{WR}) \times \frac{1}{\eta}$$

η utilisation efficiency of the expansion vessel (at pressureless elko-mat eder expansion vessels → $\eta = 100\%$)

The **filling pressure** p_{fil} is the required pressure in the system if the lowest possible temperature ϑ_{min} is not given (for filling of water make-up).

$$p_{fil} = V_N \times \frac{p_0 + 1}{V_N - V_{System} \times \left(1 - \frac{\rho_{\vartheta_{fil}}}{\rho_{\vartheta_{min}}}\right) - V_{WR}} - 1$$

p_{fil} filling pressure [bar]

p_0 gas pressure [bar]

V_N nominal volume of the expansion vessel [l]

V_{System} total content of the system [l]

V_{WR} water reserve [l]

$\rho_{\vartheta_{fil}}$ density of the medium at the current system temperature during fill or make-up process [kg/m³] (table 5)

$\rho_{\vartheta_{min}}$ density of the medium at the lowest system temperature [kg/m³] (table 5)

calculation example:

Determine the filling pressure p_{fil} for the above mentioned system.

solution:

given: $p_0 = 1 \text{ bar}$

$V_N = 50 \text{ litres}$

$V_{System} = 320 \text{ litres}$

$V_{WR} = 3 \text{ litres}$

current system temp. = 60 °C

asked for: filling pressure p_{fil} of the system

$\vartheta_{fil} = 60 \text{ °C}$

→ $\rho_{\vartheta_{fil}} = 983,1 \text{ kg/m}^3$

$$p_{fil} = V_N \times \frac{p_0 + 1}{V_N - V_{System} \times \left(1 - \frac{\rho_{\vartheta_{fil}}}{\rho_{\vartheta_{min}}}\right) - V_{WR}} - 1$$

$$p_{fil} = 50 \times \frac{1 + 1}{50 - 320 \times \left(1 - \frac{983,1}{999,7}\right) - 3} - 1$$

$p_{fil} = \underline{1,40 \text{ bar}}$

The filling pressure p_{fil} is 1,40 bar.

3.2 Expansion vessels for warm water sanitary systems

elko-san eder San D series expansion vessels are mainly used in sealed warm water sanitary systems.

They prevent opening and thus the crusting of the safety valves during preparation of warm water, precious water can't get lost during heating-up.

Due to the special construction the water can flow through the vessel. Therefore the increasing hygienic requirements get fulfilled. The diaphragm is made of food-safe and tasteless material, connection and flange are made of stainless steel.

Because of the usage in drinking water systems, a professional installation must be ensured. Relevant standards and regulations (e.g. EN 806 part 1 to 5) must be observed! The hydraulic connection must be made in the cold water inlet to the water heater, a usage on the hot water side is not permitted.

To prevent a hygienic impairment of the drinking water, water stagnation must be prevented reliably. A constant high ambient temperature at the installation site (e.g. 30 °C or higher), thereby heated cold water and too little consumption of the drinking water at the same time (less than 72h a consumption) can affect the water hygiene negatively e.g. the development of odours.

This is not caused by the expansion vessel and thus any warranty must be excluded. Instead, the installation of the drinking water system must be checked for a standard-compliant design and if necessary it must be updated to the latest technical standards!

The flow through of the vessel is ensured by using a throttle valve. This valve must be closed to such an extent that the flow through the vessel is ensured, but the total flow rate of the drinking water system is not affected negatively.

Caution: elko-san eder San D expansion vessels are installed to the system via 2 pcs. elko-flex eder maintenance units.

The gas pressure (acc. to the calculation) must be set during commissioning.

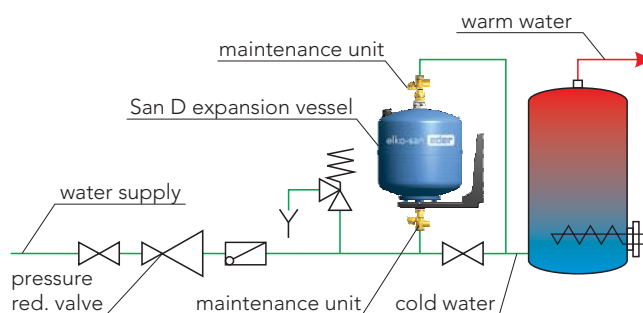

An adequate sizing ensures the compliance of the points mentioned above and guarantees a problem-free operation.

To calculate an elko-san eder San D series expansion vessel the following technical specifications of the systems are necessary:

- volume of the water boiler
- max. warm water temperature
- inlet pressure (=set pressure of the pressure reducing valve)
- set pressure of the safety valve

The adjoining diagrams can be used to simplify the sizing of elko-san eder San D expansion vessels.

The sizing is based on a gas pressure of 0,3 bar lower than the set pressure of the pressure reducing valve in the water supply. The reduced volume of the vessel, caused by the water reserve resp. expansion factors acc. to standard is already considered.

selection diagram 1:

set pressure p_{SV} of the safety valve: 6 bar inlet pressure (pressure reducing valve): 3,8 bar
 final pressure p_{fin} : 5,4 bar gas pressure p_0 within the expansion vessel: 3,5 bar

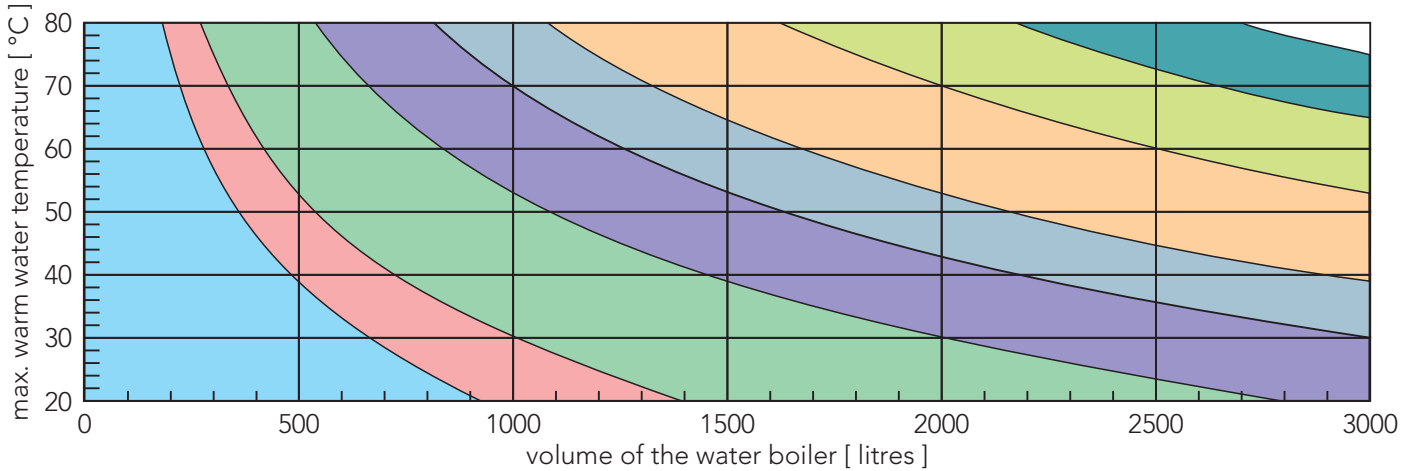

selection diagram 2:

set pressure p_{SV} of the safety valve: 10 bar inlet pressure (pressure reducing valve): 3,8 bar
 final pressure p_{fin} : 9,4 bar gas pressure p_0 within the expansion vessel: 3,5 bar

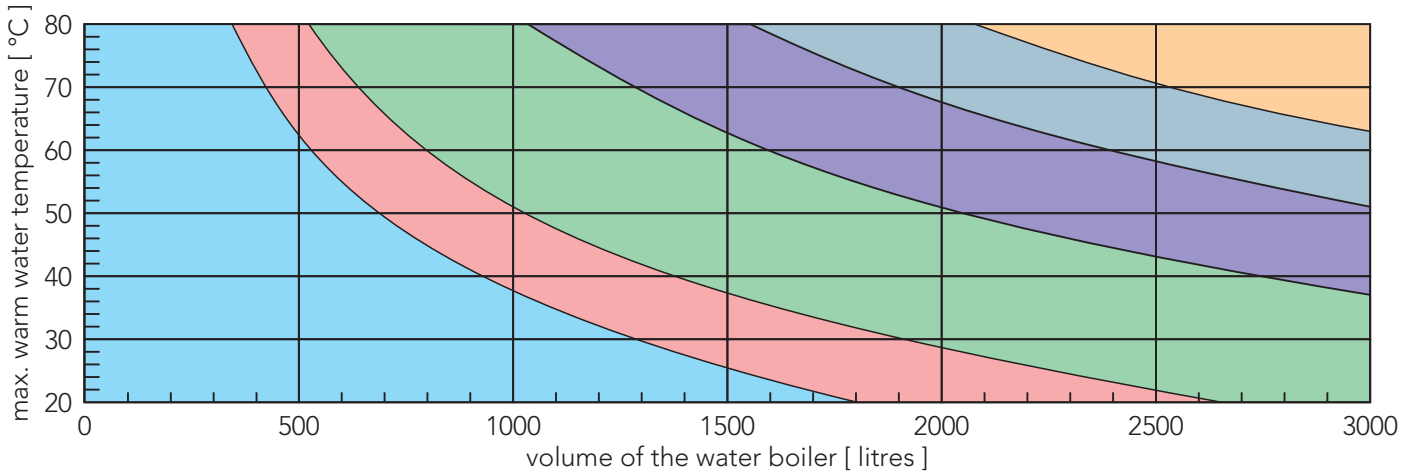

selection diagram 3:

set pressure p_{SV} of the safety valve: 10 bar inlet pressure (pressure reducing valve): 7 bar
 final pressure p_{fin} : 9,4 bar gas pressure p_0 within the expansion vessel: 6,7 bar

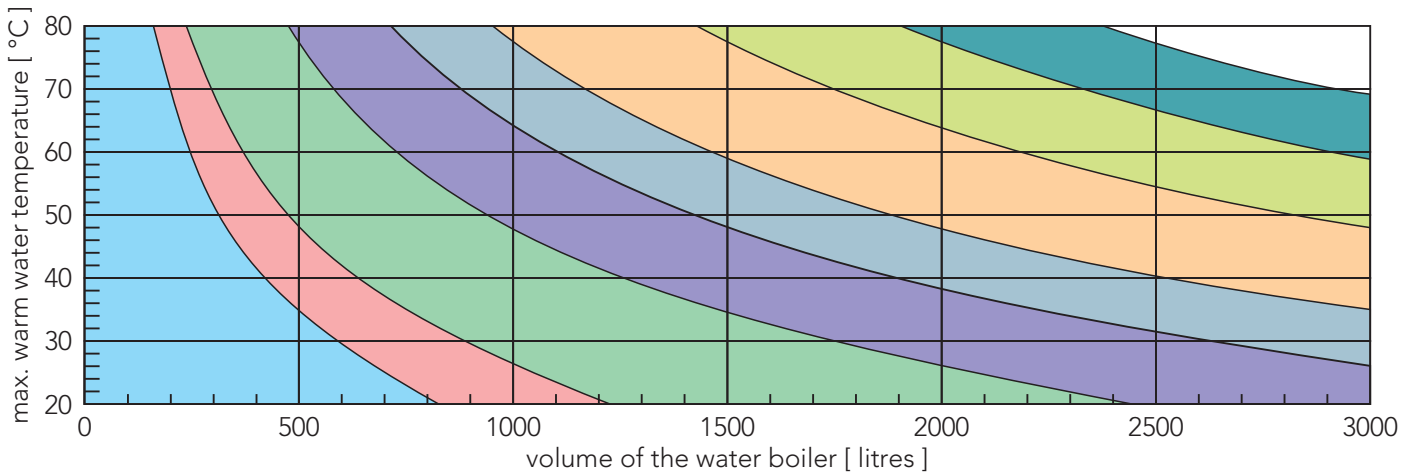

- | | | | |
|----------|----------|-----------|-----------|
| San 20 D | San 60 D | San 120 D | San 240 D |
| San 30 D | San 90 D | San 180 D | San 300 D |

3.3 Safety expansion vessels for refrigeration systems

elko-flex eder Cool series safety expansion vessels are designed to use in refrigeration systems (cold water systems, chillers)

The diaphragms are resistant to common antifreeze fluids based on glycol. The connection flange is made of stainless steel.

3.3.1 hydraulic connection

elko-flex eder Cool series safety expansion vessels are designed for wall mounting. Generally the vessel is installed with the connection on the bottom and a pipe loop to the system return. Thus the diaphragm is protected against too cold temperatures in refrigeration systems.

The operating temperature of elko-flex eder Cool safety expansion vessels is between -10 °C und +70 °C. Outside of this range the vessel must be protected with an EV cooling vessel.

The expansion pipe must be installed in a way that no cushion air can be enclosed. Otherwise a proper venting device must be installed.

3.3.2 Sizing of safety expansion vessels for refrigeration systems*:

* sizing follows EN 12828.

An adequate sizing of the expansion vessel ensures the compliance with the pressure limits over the entire temperature range and guarantees a problem-free operation.

Depending on situation and type of the elko-flex eder Cool expansion vessel the volume must be calculated in a way that the maximum operating pressure does not exceed at the maximum operating temperature. Also unwanted low pressure must be avoided in case of too low temperatures (e.g. negative temperatures).

To ensure maintenance without emptying the system, the vessel must be installed with a maintenance unit.

example: elko-flex eder Cool

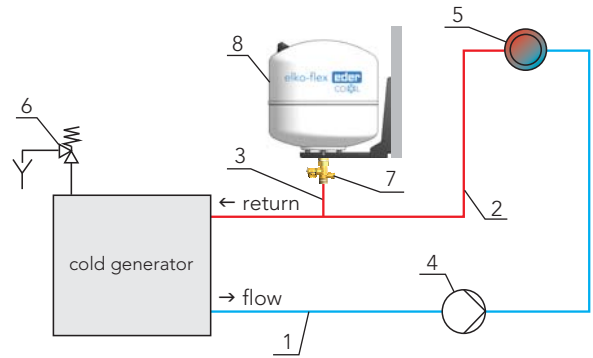

- | | |
|------------------------|---|
| 1 ... system flow | 7 ... elko-flex eder maintenance unit |
| 2 ... system return | 8 ... elko-flex eder Cool safety expansion vessel |
| 3 ... expansion pipe | |
| 4 ... circulation pump | |
| 5 ... load | |
| 6 ... safety valve | |

To calculate an elko-flex eder Cool series safety expansion vessel the following technical specifications of the system are necessary:

- total content of the refrigeration system V_{System} [l]
- max. ambient temperature ϑ_{max} which can occur at standstill of the cold generator [°C]
- min. temperature ϑ_{min} in the refrigeration system, corresponds to the lowest flow temperature of the cold generator [°C]
- static height pressure p_{st} [bar]
- max. operating pressure p_{SV} of the system [bar]

The correct **gas pressure** p_0 (=minimum operating pressure) avoids low pressure (with the result of diffusion etc.) in low temperature situations of normal operating systems. Therefore an addition to the static height pressure p_{st} should be considered preventively, whereby the minimum operating pressure is higher than necessary.

$$p_0 = p_{st} + 0,2$$

p_0 min. operating pressure = gas pressure [bar]
 p_{st} static height pressure - pressure only resulting from the difference in height h_{st} between the position of the pressurization system and the highest point of the refrigeration system
 10 meter water column (mWs) ~ 1 bar

Calculation of the **expansion volume** V_{ex} :

$$V_{ex} = V_{System} \times e$$

$$e = 1 - \frac{\rho_{gmax}}{\rho_{gmin}}$$

e expansion coefficient
 ρ_{gmax} density of the medium (e.g. water/antifreeze mix) at ambient temperature [kg/m³] (table 5)
 ρ_{gmin} density of the medium at the lowest flow temperature [kg/m³] (table 5)

Used additive substances can affect the material of the diaphragm!

Calculation of the **water reserve** V_{WR} :

$$V_{WR} = \frac{V_N \times 20}{100} \quad \text{if } V_N \leq 15 \text{ l}$$

$$V_{WR} = \frac{V_{System} \times 0,5}{100} \geq 3 \quad \text{if } V_N > 15 \text{ l}$$

V_{WR} water reserve [l]
 V_N nominal volume of the expansion vessel [l]
 V_{system} total content of the system [l]

Usually in Austria the **minimum set pressure of the safety valve** p_{sv} is defined with 2 bar above the static pressure p_{st} , at least 3 bar!

$$p_{sv} = p_{st} + 2 \geq 3 \text{ bar}$$

The **final pressure** p_{fin} indicates the highest pressure in the operating range of the refrigeration system. It should not be higher than the set pressure of the safety valve minus a difference in shut-off overpressure, the so-called closing pressure difference p_{SD} .

According to EN ISO 4216-1 a closing pressure difference of 20 %, at least 0,6 bar is admissible.

$$p_{SD} = p_{sv} \times 20 \% \geq 0,6 \text{ bar}$$

$$p_{fin} = p_{sv} - p_{SD}$$

p_{SD} closing pressure difference [bar]
 p_{sv} set pressure of the safety valve [bar]
 p_{fin} final pressure [bar]

Note: The standard ÖNORM H 5151-1 specifies the closing pressure difference p_{SD} with 10 % of the set pressure (blow-off pressure) of the safety valve, at least 0,5 bar.

Calculation of the **minimum nominal volume** $V_{N,min}$ of diaphragm expansion vessels:

$$V_{N,min} = (V_{ex} + V_{WR}) \times \frac{p_{fin} + 1}{p_{fin} - p_0}$$

$V_{N,min}$ minimum nominal volume [l]
 V_{ex} expansion volume [l]
 V_{WR} water reserve [l]
 p_{fin} final pressure [bar]
 p_0 gas pressure [bar]

Selection and correct sizing of the diaphragm expansion vessel:

$$V_N \geq V_{N,min}$$

For diaphragm expansion vessels the initial pressure p_{ini} shall be confirmed for the selected vessel as follows:

$$p_{ini} = \frac{p_{fin} + 1}{1 + \frac{V_{ex}}{V_N} \times \frac{p_{fin} + 1}{p_0 + 1}} - 1$$

The correct sizing of the expansion vessel is ensured as long as:

$$p_{ini} \geq p_0 + 0,3 \text{ bar}$$

Otherwise the nominal volume V_N should be increased until the condition above is met.

During **filling of cold water systems** special attention must be paid to the current operating mode of the system. It must be differentiated whether the system gets filled for the first time or a make-up process takes place (e.g. during maintenance).

Calculation of the **filling pressure p_{fil}** for the first fill of a cold water system:

$$p_{fil} = V_N \times \frac{p_0 + 1}{V_N - V_{System} \times \left(1 - \frac{\rho_{\vartheta_{fil}}}{\rho_{\vartheta_{min}}}\right) - V_{WR}} - 1$$

- p_{fil} filling pressure [bar]
- p_0 gas pressure [bar]
- V_N nominal volume of the expansion vessel [l]
- V_{System} total content of the system [l]
- V_{WR} water reserve [l]
- $\rho_{\vartheta_{fil}}$ density of the medium at filling temperature [kg/m³] (table 5) *
- $\rho_{\vartheta_{min}}$ density of the medium at the lowest flow temperature [kg/m³] (table 5)

* If the system gets filled with water, the filling temperature is 10 °C (in general). Depending on the storage temperature of the added antifreeze fluid the temperature of the medium could be higher.

Calculation of the **filling pressure p_{erg}** for make-up (=supplement pressure):

$$p_{erg} = V_N \times \frac{p_0 + 1}{V_N - V_{System} \times \left(1 - \frac{\rho_{\vartheta_{erg}}}{\rho_{\vartheta_{min}}}\right) - V_{WR}} - 1$$

- p_{erg} filling pressure (=supplement pressure) [bar]
- p_0 gas pressure [bar]
- V_N nominal volume of the expansion vessel [l]
- V_{System} total content of the system [l]
- V_{WR} water reserve [l]
- $\rho_{\vartheta_{erg}}$ density of the medium at the current system temperature during make-up process [kg/m³] (table 5)
- $\rho_{\vartheta_{min}}$ density of the medium at the lowest flow temperature [kg/m³] (Tabelle 5)

calculation example:

Calculate the appropriate diaphragm expansion vessel for a refrigeration system:

solution:

- given: $h_{st} = 2 \text{ mWs} \rightarrow p_{st} = 0,2 \text{ bar}$
 $V_{System} = 280 \text{ litres}$
 ethylene glycol 34 % (up to -20 °C)
 $\vartheta_{max} = 30 \text{ °C}$
 $\vartheta_{min} = -10 \text{ °C}$
 $p_{SV} = 3 \text{ bar}$
- asked for: appropriate expansion vessel
 filling pressure for first fill
 filling pressure for make-up

$$p_0 = p_{st} + 0,2 = 0,2 + 0,2 = 0,4 \rightarrow \text{set } 1 \text{ bar}$$

$$e = 1 - \frac{\rho_{\vartheta_{max}}}{\rho_{\vartheta_{min}}} = 1 - \frac{1045}{1064} = 1,8 \%$$

$$V_{ex} = V_{System} \times e = 280 \times 0,018 = 5,04 \text{ l}$$

$$V_{WR} = \frac{V_{System} \times 0,5}{100} \geq 3$$

$$V_{WR} = \frac{280 \times 0,5}{100} = 1,4 \text{ l} \rightarrow V_{WR} = 3 \text{ l}$$

$$p_{SV} = p_{st} + 2$$

$$= 0,2 + 2 = 2,2 \rightarrow \text{set: } p_{SV} = 3 \text{ bar}$$

$$p_{SD} = p_{SV} \times 20 \% \geq 0,6 \text{ bar}$$

$$= 3 \times 0,2 = 0,6 \rightarrow p_{SD} = 0,6 \text{ bar}$$

$$p_{fin} = p_{SV} - p_{SD} = 3 - 0,6 = 2,4 \text{ bar}$$

$$V_{N,min} = (V_{ex} + V_{WR}) \times \frac{p_{fin} + 1}{p_{fin} - p_0}$$

$$V_{N,min} = (5,04 + 3) \times \frac{2,4 + 1}{2,4 - 1} = \underline{19,5 \text{ l}}$$

→ selected vessel: elko-flex eder Cool 25
nominal volume V_N : 25 litres
max. operating pressure: 6 bar
max. long-term temperature: 70 °C

$$p_{ini} = \frac{p_{fin} + 1}{1 + \frac{V_{ex}}{V_N} \times \frac{p_{fin} + 1}{p_0 + 1}} - 1$$

$$p_{ini} = \frac{2,4 + 1}{1 + \frac{5,04}{25} \times \frac{2,4 + 1}{1 + 1}} - 1 = 1,54 \text{ bar}$$

$$p_{ini} \geq p_0 + 0,3 \text{ bar}$$

$$p_{ini} \geq 1 + 0,3 \text{ bar} = 1,3 \text{ bar}$$

The required term is fulfilled, the selected elko-flex eder Cool 25 can be used.

matching maintenance unit:
elko-flex eder maintenance unit 3/4" a/i

For the first fill of the cold water system, the used medium is a water/antifreeze mix with 34 % ethylene glycol, the storage temperature is $\vartheta_{fil} = 20 \text{ °C} \rightarrow \rho_{\vartheta_{fil}} = 1050 \text{ kg/m}^3$

$$p_{fil} = V_N \times \frac{p_0 + 1}{V_N - V_{System} \times \left(1 - \frac{\rho_{\vartheta_{fil}}}{\rho_{\vartheta_{min}}}\right) - V_{WR}} - 1$$

$$= 25 \times \frac{1 + 1}{25 - 280 \times \left(1 - \frac{1050}{1064}\right) - 3} - 1$$

$$p_{fil} = \underline{1,73 \text{ bar}}$$

The necessary filling pressure for first fill is 1,73 bar.

asked for: Filling pressure for make-up during annual maintenance.

During maintenance the average temperature of the cold water system is $\vartheta_{erg} = -5 \text{ °C} \rightarrow \rho_{\vartheta_{erg}} = 1062 \text{ kg/m}^3$

$$p_{erg} = V_N \times \frac{p_0 + 1}{V_N - V_{System} \times \left(1 - \frac{\rho_{\vartheta_{erg}}}{\rho_{\vartheta_{min}}}\right) - V_{WR}} - 1$$

$$= 25 \times \frac{1 + 1}{25 - 280 \times \left(1 - \frac{1062}{1064}\right) - 3} - 1$$

$$p_{erg} = \underline{1,33 \text{ bar}}$$

The necessary filling pressure for make-up p_{erg} (=supplement pressure) is 1,33 bar

Note: According to ÖNORM H 5151-1 a pump-controlled pressurization device is state of the art in larger systems (nominal power 100 kW and higher, total content 5000 litres and higher or 100 m² solar collector area)

The nominal volume $V_{N,min}$ of these expansion vessels is determined as follows (acc. to EN 12828):

$$V_{N,min} = (V_{ex} + V_{WR}) \times \frac{1}{\eta}$$

η utilisation efficiency of the expansion vessel (at pressureless elko-mat eder expansion vessels $\rightarrow \eta = 100 \%$)

calculation example:

Calculate the correct expansion vessel for a cold water system. The static height of the system is 12 mWs, the system is filled with 450 litres of water.

The flow temperature of the system is 5 °C, the ambient temperature is 30 °C.

solution:

given: $h_{st} = 12 \text{ mWs} \rightarrow p_{st} = 1,2 \text{ bar}$
 $V_{System} = 450 \text{ litres}$
 $\vartheta_{max} = 30 \text{ °C}$
 $\vartheta_{min} = 5 \text{ °C}$

asked for: appropriate expansion vessel
 filling pressure for first fill
 filling pressure für make-up

$$p_0 = p_{st} + 0,2 = 1,2 + 0,2 = 1,4 \rightarrow \text{set } 2 \text{ bar}$$

$$e = 1 - \frac{\rho_{\vartheta_{max}}}{\rho_{\vartheta_{min}}} = 1 - \frac{995,7}{999,9} = 0,4 \%$$

$$V_{ex} = V_{System} \times e = 230 \times 0,004 = 1,8 \text{ l}$$

$$V_{WR} = \frac{V_{System} \times 0,5}{100} \geq 3$$

$$V_{WR} = \frac{450 \times 0,5}{100} = 2,25 \text{ l} \rightarrow V_{WR} = 3 \text{ l}$$

$$p_{SV} = p_{st} + 2$$

$$= 1,2 + 2 = 3,2 \rightarrow \text{set: } p_{SV} = 6 \text{ bar}$$

$$p_{SD} = p_{SV} \times 20 \% \geq 0,6 \text{ bar}$$

$$= 6 \times 0,2 = 1,2 \rightarrow p_{SD} = 1,2 \text{ bar}$$

$$p_{fin} = p_{SV} - p_{SD} = 6 - 1,2 = 4,8 \text{ bar}$$

$$V_{N,min} = (V_{ex} + V_{WR}) \times \frac{p_{fin} + 1}{p_{fin} - p_0}$$

$$V_{N,min} = (1,8 + 3) \times \frac{4,8 + 1}{4,8 - 1} = \underline{7,33 \text{ l}}$$

→ selected vessel: elko-flex eder Cool 18
 nominal volume V_N : 18 litres

$$p_{ini} = \frac{p_{fin} + 1}{1 + \frac{V_{ex}}{V_N} \times \frac{p_{fin} + 1}{p_0 + 1}} - 1$$

$$p_{ini} = \frac{4,8 + 1}{1 + \frac{7,33}{18} \times \frac{4,8 + 1}{1 + 1}} - 1 = 1,66 \text{ bar}$$

$$p_{ini} \geq p_0 + 0,3 \text{ bar} = 1 + 0,3 = 1,3 \text{ bar}$$

The required term is fulfilled, the selected elko-flex eder Cool 18 can be used.

The cold water system is filled with water with a filling temperature of $\vartheta_{fil} = 10 \text{ °C}$
 $\rightarrow \rho_{\vartheta_{fil}} = 999,8 \text{ kg/m}^3$

$$p_{fil} = V_N \times \frac{p_0 + 1}{V_N - V_{System} \times \left(1 - \frac{\rho_{\vartheta_{fil}}}{\rho_{\vartheta_{min}}}\right) - V_{WR}} - 1$$

$$= 18 \times \frac{2 + 1}{18 - 450 \times \left(1 - \frac{999,8}{999,9}\right) - 3} - 1$$

$$p_{fil} = \underline{2,61 \text{ bar}}$$

The necessary filling pressure for first fill is 2,61 bar.

The make-up happens in deactivated status of the cold water system. At that time the average system temperature is $\vartheta_{erg} = 15 \text{ °C}$
 $\rightarrow \rho_{\vartheta_{erg}} = 999,2 \text{ kg/m}^3$

$$p_{erg} = V_N \times \frac{p_0 + 1}{V_N - V_{System} \times \left(1 - \frac{\rho_{\vartheta_{erg}}}{\rho_{\vartheta_{min}}}\right) - V_{WR}} - 1$$

$$= 18 \times \frac{2 + 1}{18 - 450 \times \left(1 - \frac{999,2}{999,9}\right) - 3} - 1$$

$$p_{erg} = \underline{2,68 \text{ bar}}$$

The necessary filling pressure for make-up p_{erg} (=supplement pressure) is 2,68 bar

3.4 Safety expansion vessels for solar systems

elko-flex eder Solar series safety expansion vessels are designed to use in solar systems.

The diaphragms are resistant to common antifreeze fluids based on glycol. The connection flange is made of stainless steel.

3.4.1 hydraulic connection

Depending on type and construction of the elko-flex eder Solar safety expansion vessel, it must be mounted to the wall (up to Solar 60) or to the ground (Solar 90 and higher).

Generally the vessel is installed with the connection on the bottom and a pipe loop to the system return. Thus the vessel is protected against too high temperatures which affect the lifetime of the diaphragm.

The maximum long-term temperature of the diaphragm is 70 °C. If the temperature can exceed, the vessel must be protected with an EV cooling vessel.

The expansion pipe must be installed in a way that no cushion air can be enclosed. Otherwise a

proper venting device must be installed.

To ensure maintenance without emptying the system, the vessel must be installed with a maintenance unit.

example: elko-flex eder Solar safety expansion vessel in hanging position

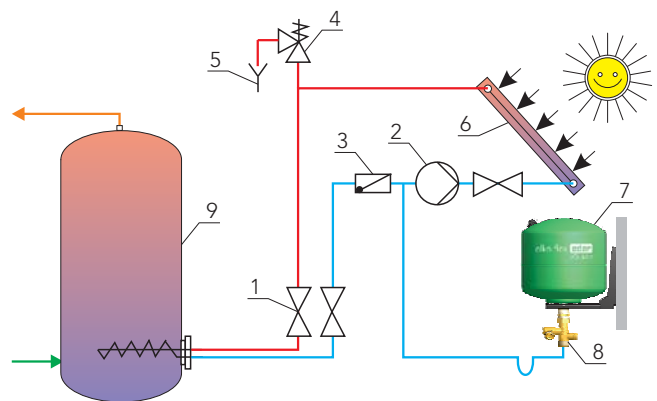

- | | |
|------------------------|--|
| 1 ... cut-off device | 7 ... elko-flex eder Solar safety expansion vessel |
| 2 ... circulation pump | 8 ... elko-flex eder maintenance unit |
| 3 ... check valve | 9 ... warm water boiler |
| 4 ... safety valve | |
| 5 ... safety drain | |
| 6 ... collector | |

3.4.2 Sizing of diaphragm expansion vessels for solar systems*:

* sizing follows EN 12828.

An adequate sizing of the expansion vessel ensures the compliance with the pressure limits over the entire temperature range and guarantees a problem-free operation.

Depending on the situation and type of the elko-flex eder Solar expansion vessel the volume must be calculated in a way that the maximum operating pressure does not exceed at the maximum operating temperature. Also unwanted low pressure must be avoided in case of too low temperatures (e.g. negative temperatures).

To calculate an elko-flex eder Solar series safety expansion vessel the following technical specifications of the system are necessary:

- total content of the solar system V_{System} [l]
- total content of the collector V_k [l]
- max. standstill temperature [°C]
- max. temperature ϑ_{max} to prevent the content of the collector from evaporating [°C]
- static height pressure p_{st} [bar]
- max. operating pressure p_{SV} of the system [bar]

The correct **gas pressure** p_0 (=minimum operating pressure) avoids evaporating of the medium in normal operating mode of the solar system. Also it avoids low pressure (with the result of diffusion etc.) during cooling down and at standstill of the system in winter.

$$p_0 = p_{st} + 0,2 + p_v$$

- p_0 min. operating pressure = gas pressure (effectively avoiding evaporation, cavitation, vacuum) = nominal inlet pressure of the pressurization system [bar]
- p_{st} static height pressure - pressure only resulting from the difference in height h_{st} between the position of the pressurization system and the highest point of the solar system
10 meter water column (mWs) ~ 1 bar
- p_v vapour pressure [bar] at temperature ϑ_{max}
Specific values for common antifreeze fluids are specified in table 3

Calculation of the **expansion volume** V_{ex} :

$$V_{ex} = V_{System} \times e$$

$$e = 1 - \frac{\rho_{\vartheta_{max}}}{\rho_{\vartheta_{min}}}$$

- e expansion coefficient
- $\rho_{\vartheta_{max}}$ density of the medium (e.g. water/antifreeze mix) at the maximum temperature before evaporation [kg/m³] (table 5)
- $\rho_{\vartheta_{min}}$ density of the medium at filling temperature [kg/m³] (table 5)

Usually the filling temperature is specified with 10 °C.

Used additive substances can affect the material of the diaphragm!

Calculation of the **water reserve** V_{WR} :

$$V_{WR} = \frac{V_N \times 20}{100} \quad \text{if } V_N \leq 15 \text{ l}$$

$$V_{WR} = \frac{V_{System} \times 0,5}{100} \geq 3 \quad \text{if } V_N > 15 \text{ l}$$

- V_{WR} water reserve [l]
- V_N nominal volume of the expansion vessel [l]
- V_{System} total content of the system [l]

Usually the **minimum set pressure of the safety valve** p_{sv} is defined with 2 bar above the static pressure p_{str} at least 3 bar!

$$p_{sv} = p_0 + 2 \geq 3 \text{ bar}$$

The **final pressure** p_{fin} indicates the highest pressure in the operating range of the solar system. It should not be higher than the set pressure of the safety valve minus a difference in shut-off overpressure, the so-called closing pressure difference p_{SD} .

According to EN ISO 4216-1 a closing pressure difference of 20 %, at least 0,6 bar is admissible.

$$p_{SD} = p_{sv} \times 20 \% \geq 0,6 \text{ bar}$$

$$p_{fin} = p_{sv} - p_{SD}$$

- p_{SD} closing pressure difference [bar]
- p_{sv} set pressure of the safety valve [bar]
- p_{fin} final pressure [bar]

Note: The standard ÖNORM H 5151-1 specifies the closing pressure difference with 10 % of the set pressure (blow-off pressure) P_{sv} of the safety valve, at least 0,5 bar.

Calculation of the **minimum nominal volume** $V_{N,min}$ of diaphragm expansion vessels:

It must be considered, that the content of the collector (or at least a part of it) can be heated to

the standstill temperature of the collector. The standstill temperature depends on the collector and can exceed 160 °C, it must be requested from the manufacturer.

Due to this high temperatures, the content of the collector can evaporate, thus the medium is protected against further rising temperatures.

Note: Most antifreeze fluids based on propylene glykol are suitable for long-term temperatures of max. 170 °C. Higher temperatures result in faster aging and thermal decomposition of the antifreeze fluid.

Therefore expansion vessels must be sized big enough to accommodate the content of the collector V_K :

$$V_{N,min} = (V_{ex} + V_K + V_{WR}) \times \frac{p_{fin} + 1}{p_{fin} - p_0}$$

- V_{ex} expansion volume [l]
- V_K total content of the collector (as declared by the manufacturer of the collector) [l]
- V_{WR} water reserve [l]
- p_{fin} final pressure [bar]
- p_0 gas pressure [bar]

If the expansion vessel is sized too small, the system pressure exceeds the set pressure of the safety valve. The safety valve opens and medium gets lost. During cooling down this medium is missing, diffusion would be the consequence.

Selection and correct sizing of the diaphragm expansion vessel:

$$V_N \geq V_{N,min}$$

For diaphragm expansion vessels the initial pressure p_{ini} shall be confirmed for the selected vessel as follows:

$$p_{ini} = \frac{p_{fin} + 1}{1 + \frac{V_{ex} + V_K}{V_N} \times \frac{p_{fin} + 1}{p_0 + 1}} - 1$$

The correct sizing of the expansion vessel is ensured as long as:

$$p_{ini} \geq p_0 + 0,3 \text{ bar}$$

Otherwise the nominal volume V_N should be increased until the condition above is met.

Calculation of the **filling pressure p_{fil}** of the solar system in cold state:

$$p_{fil} = V_N \times \frac{p_0 + 1}{V_N - V_{System} \times \left(1 - \frac{\rho_{\vartheta fil}}{\rho_{\vartheta min}}\right) - V_{WR}} - 1$$

- p_{fil} filling pressure [bar]
- p_0 gas pressure [bar]
- V_N nominal volume of the expansion vessel [l]
- V_{System} total content of the system [l]
- V_{WR} water reserve [l]
- $\rho_{\vartheta fil}$ density of the medium at the current system temperature during fill or make-up process [kg/m³] (table 5)
- $\rho_{\vartheta min}$ density of the medium at the lowest system temperature [kg/m³] (table 5)

calculation example:

Calculate the appropriate diaphragm expansion vessel for a solar system:

solution:

- given: $h_{st} = 12 \text{ mWs} \rightarrow p_{st} = 1,2 \text{ bar}$
- $V_{System} = 37 \text{ litres}$
- $V_K = 18 \text{ litres}$
- propylene glycol 39% (-20 °C)
- evaporation at 120 °C
- asked for: appropriate expansion vessel

3.5 Sizing with online design program elko-online 2.0

Explanation of the procedure using the following example:

Determine the appropriate diaphragm expansion vessel for a heating system, which consists of a Biovent C15 and a akku ESP 1000 buffer tank using the online design program elko-online2.0.

given: power Φ_{NL} of the heat generator = 15 kW

$$\vartheta_{\text{flow}} = 85^\circ\text{C} \quad V_{\text{System}} = 1.300\text{l}$$

$$\vartheta_{\text{return}} = 65^\circ\text{C} \quad h_{\text{st}} = 6\text{ mWs}$$

$$\vartheta_{\text{max}} = 90^\circ\text{C} \quad p_{\text{SV}} = 3\text{ bar}$$

asked for: appropriate expansion vessel
necessary gas pressure p_0 within the vessel

1. Start the design program online at:

<http://elko-online.eder-heizung.at> and

enter the data of your system (figure 1).

2. By clicking the "calculate" button, you are taken to the interim result page.

This page shows the results of the calculation and the appropriate products resp. expansion vessels (figure 2).

3. After selecting the required variant and the suitable accessory click the "finish" button. This opens the result page, where your selected products are summarized. Furthermore it shows the necessary gas pressure for the current system and the appropriate filling pressure of the cold system (figure 3).

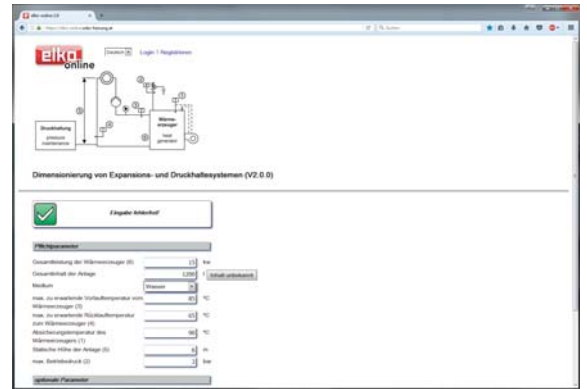

figure 1

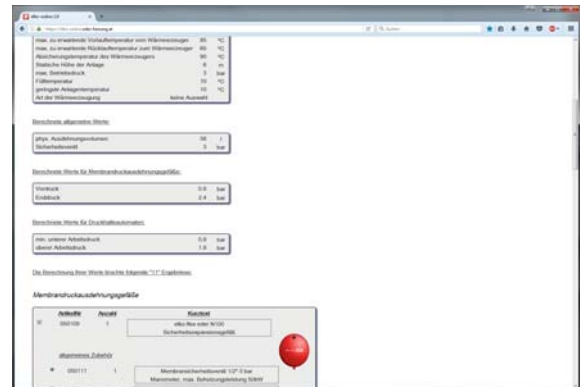

figure 2

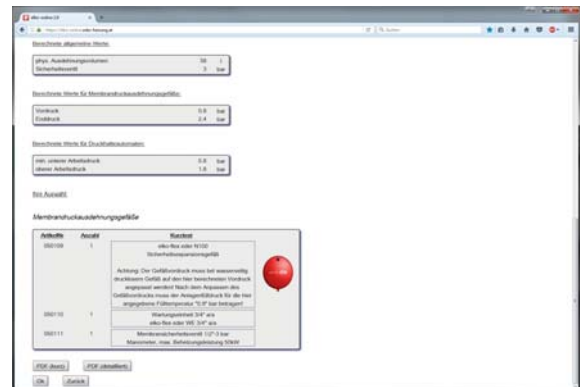

figure 3

Result:

- appropriate expansion vessel:
elko-flex eder N 100
- necessary gas pressure p_0 :
 $p_0 = 0,8\text{ bar}$

If you want to save your calculation or get a corresponding offer, you need to register at elko-online 2.0. As an unregistered user you can't use these additional functions.

In both cases you can print the result for your further use.

<http://elko-online.eder-heizung.at>

3.7 Tables

table 1:

 plant-specific water content f_{an}

system type resp. type of heat emitters	plant-specific water content f_{an} [l / kW]
boiler, radiators, UFH	ca. 17
gravitational heating	ca. 17
under floor heating	ca. 17
boiler, sectional radiators	ca. 15
boiler, flat radiators	ca. 13
flow heaters, air heaters	ca. 9
convectors	ca. 9

table 2:

minimum nominal size of the expansion pipe in systems with a nominal power lower than 500 kW acc. to ÖNORM H 5151-1

DN	nom. power of the heat generator [kW]
20	up to 120
25	from 120 to 500

The max. flow rate within the expansion pipe must not exceed 0,15 m/s.

table 3:

 relative vapour pressure p_v of water and common antifreeze fluids

temperature [°C]	relative vapour pressure p_v [bar]						
	water	ethylene glycol			propylene glykol		
		23 % vol. (to -10 °C)	34 % vol. (to -20 °C)	44 % vol. (to -30 °C)	27 % vol. (to -10 °C)	39 % vol. (to -20 °C)	47 % vol. (to -30 °C)
103	0,13	0,04	-	-	0,04	-	-
104	0,17	0,08	0,02	-	0,08	0,02	-
105	0,21	0,11	0,06	-	0,11	0,05	-
106	0,25	0,15	0,09	0,02	0,15	0,09	0,04
107	0,29	0,19	0,13	0,06	0,19	0,13	0,07
108	0,34	0,24	0,17	0,1	0,23	0,17	0,11
109	0,39	0,28	0,21	0,14	0,28	0,21	0,15
110	0,43	0,32	0,25	0,17	0,32	0,25	0,19
120	0,99	0,83	0,74	0,63	0,83	0,74	0,66
130	1,7	1,49	1,36	1,22	1,50	1,36	1,26
140	2,62	2,34	2,16	1,97	2,34	2,16	2,02
150	3,76	3,4	3,17	2,91	3,4	3,17	2,98
160	5,18	4,71	4,42	4,09	4,72	4,42	4,18

table 4:

water content of various pipes

threaded steel tube, medium heavy, welded, acc. to EN 10255			steel tube, welded acc. to EN 10217-1		copper tube acc. to EN 1057	
dimension [mm]	D_A [mm]	pipe content [l / m]	dimension [mm]	pipe content [l / m]	dimension [mm]	pipe content [l / m]
15 (1/2")	21,3	0,20	60,3 x 2,3	2,44	15 x 1	0,13
20 (3/4")	26,9	0,37	76,1 x 2,6	3,95	18 x 1	0,20
25 (1")	33,7	0,58	88,9 x 2,9	5,42	22 x 1	0,31
32 (5/4")	42,4	1,01	114,3 x 3,2	9,14	28 x 1,5	0,49
40 (6/4")	48,3	1,37	139,7 x 3,6	13,79	35 x 1,5	0,80

table 5:
density ρ of water and common antifreeze fluids

temperature [°C]	density ρ [kg/m ³]						
	water	ethylene glycol			propylene glycol		
		23 % vol. (to -10 °C)	34 % vol. (to -20 °C)	44 % vol. (to -30 °C)	27 % vol. (to -10 °C)	39 % vol. (to -20 °C)	47 % vol. (to -30 °C)
-30	983,0	1052	1072	1090	1046	1063	1074
-25	989,6	1050	1070	1088	1044	1061	1071
-20	992,8	1049	1068	1086	1042	1058	1068
-15	995,8	1047	1066	1084	1040	1056	1065
-10	997,8	1045	1064	1081	1038	1053	1062
-5	999,1	1043	1062	1079	1036	1050	1059
0	999,8	1041	1060	1076	1034	1048	1056
5	999,9	1039	1058	1074	1031	1045	1053
10	999,8	1037	1055	1071	1029	1042	1050
15	999,2	1035	1053	1069	1027	1039	1047
20	998,3	1033	1050	1066	1025	1037	1043
25	997,1	1030	1048	1063	1022	1034	1040
30	995,7	1028	1045	1060	1020	1031	1037
35	994,1	1025	1042	1057	1018	1028	1034
40	992,2	1023	1040	1054	1015	1025	1030
45	990,2	1020	1037	1051	1013	1022	1027
50	988,0	1018	1034	1048	1010	1019	1023
55	985,7	1015	1031	1045	1008	1016	1020
60	983,1	1012	1028	1042	1005	1013	1017
65	980,5	1010	1025	1039	1003	1010	1013
70	977,7	1007	1022	1035	1000	1006	1009
75	974,7	1004	1019	1032	997	1003	1006
80	971,6	1001	1016	1028	995	1000	1002
85	968,4	998	1012	1025	992	997	999
90	965,1	995	1009	1021	989	993	995
95	961,7	992	1005	1018	986	990	991
100	958,1	988	1002	1014	984	987	987
105	954,5	985	998	1010	981	983	984
110	950,7	982	995	1006	978	980	980
115	946,8	978	991	1002	975	976	976
120	942,8	975	987	998	972	973	972
125	938,7	971	984	994	969	969	968
130	934,6	968	980	990	966	966	964
135	930,3	964	976	986	963	962	960
140	925,9	960	972	982	960	958	956
145	921,4	957	968	977	956	954	952
150	916,8	953	964	973	953	951	948
155	912,1	949	959	969	950	947	944
160	907,3	945	955	964	947	943	940
165	902,3	941	951	960	944	939	935
170	897,3	937	947	955	940	935	931
175	892,2	932	942	950	937	931	927
180	886,9	928	938	946	933	928	922

table 6:

 quick selection table for diaphragm expansion vessels in heating systems, valid for: $p_{SV} = 3 \text{ bar}$, $\vartheta_{\max} = 110 \text{ }^\circ\text{C}$

content of the system V_{system} [l]	expansion volume V_{ex} [l]	quick selection table for diaphragm expansion vessels valid for set pressure of the safety valve $p_{SV} = 3 \text{ bar}$, $\vartheta_{\max} = 110 \text{ }^\circ\text{C}$								
		gas pressure p_0 [bar]								
		0,7	0,8	0,9	1,0	1,1	1,2	1,3	1,4	1,5
minimum nominal volume $V_{N,\min}$ of the diaphragm expansion vessel [l]										
25	1,2	8	9	10	10	11	12	13	14	16
50	2,5	11	12	12	13	14	15	17	19	21
75	3,7	13	14	15	16	17	19	21	23	25
100	4,9	16	17	18	19	21	22	24	27	30
125	6,1	18	19	21	22	24	26	28	31	35
150	7,4	21	22	23	25	27	29	32	35	39
175	8,6	23	25	26	28	30	33	36	39	44
200	9,8	26	27	29	31	34	36	40	44	48
250	12,3	31	32	35	37	40	43	47	52	58
300	14,7	35	38	40	43	46	50	55	60	67
350	17,2	40	43	46	49	53	57	62	69	76
400	19,6	45	48	51	55	59	64	70	77	86
450	22,1	50	53	57	61	66	71	78	85	95
500	24,6	55	59	62	67	72	78	85	94	104
550	27,0	60	64	68	73	78	85	93	102	113
600	29,5	65	69	74	79	85	92	100	110	123
650	31,9	70	75	80	85	92	100	109	120	133
700	34,4	76	80	86	92	99	107	117	129	143
750	36,8	81	86	92	99	106	115	125	138	153
800	39,3	87	92	98	105	113	123	134	147	164
850	41,7	92	98	104	112	120	130	142	156	174
900	44,2	97	103	110	118	127	138	151	166	184
950	46,7	103	109	117	125	134	146	159	175	194
1000	49,1	108	115	123	131	142	153	167	184	204
1100	54,0	119	126	135	145	156	169	184	202	225
1200	58,9	130	138	147	158	170	184	201	221	245
1300	63,8	141	149	159	171	184	199	217	239	266
1400	68,8	152	161	172	184	198	215	234	258	286
1500	73,7	162	172	184	197	212	230	251	276	307
1600	78,6	173	184	196	210	226	245	268	294	327
1700	83,5	184	195	209	223	241	261	284	313	348
1800	88,4	195	207	221	237	255	276	301	331	368
1900	93,3	206	218	233	250	269	291	318	350	388
2000	98,2	216	230	245	263	283	307	334	368	409
2100	103,1	227	241	258	276	297	322	351	386	429
2200	108,0	238	253	270	289	311	337	368	405	450
2300	113,0	249	264	282	302	325	353	385	423	470
2400	117,9	260	276	294	315	340	368	401	442	491
2500	122,8	271	287	307	329	354	383	418	460	511
2600	127,7	281	299	319	342	368	399	435	478	531
2700	132,6	292	310	331	355	382	414	452	497	552
2800	137,5	303	322	343	368	396	429	468	515	572
2900	142,4	314	333	356	381	410	445	485	534	593
3000	147,3	325	345	368	394	425	460	502	552	613

4. Technical data

4.1 Safety expansion vessels for heating, climatic and cold water systems

elko-flex eder N series

Safety expansion vessels for sealed heating, climatic and cold water systems acc. to EN 12828. Constructed with a non-exchangeable diaphragm to accommodate the expansion volume, gas filling with gas pressure valve, connection for a maintenance unit. Mounting is executed as single-point mount (N 4 - N 100) resp. as four-point bracketed for wall mount or installation on the floor.

- Tested in accordance with PED 2014/68/EU
- max. safety temperature of the system without/with cooling vessel: 90/110 °C
- max. temp. at the connection point: 70 °C
- max. operating pressure: 3 bar
- permissible medium: water resp. water/glycol mixture (other plant media can be checked on request)

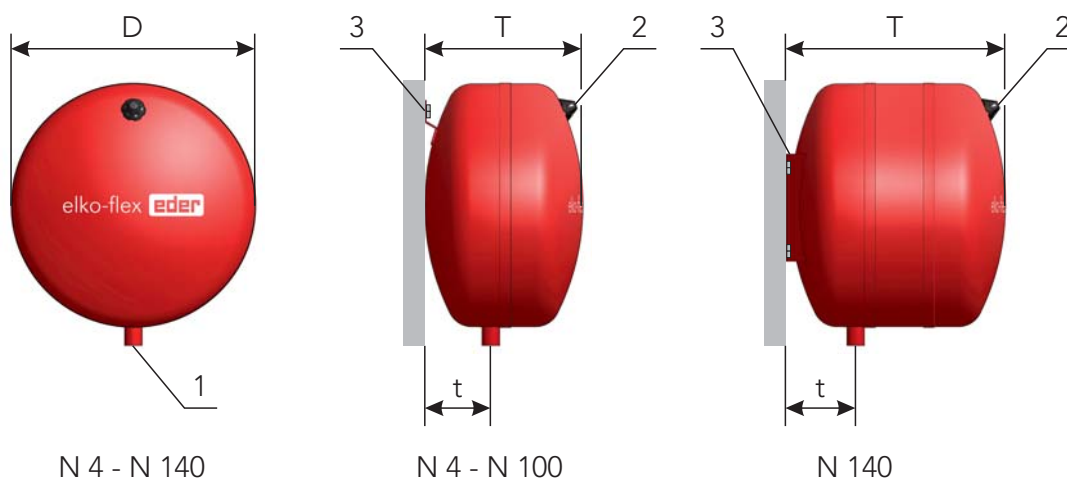

type	nom. content [Liter]	standard gas pressure [bar]	D [mm]	T [mm]	t [mm]	connection ["]	weight [kg]	colour
N 4	4	0,8	360	197	80	Rp3/4	3,5	RAL 3001
N 8	8	0,8	360	197	80	Rp3/4	3,5	RAL 3001
N 12	12	0,8	360	197	80	Rp3/4	3,5	RAL 3001
N 18	18	0,8	360	237	80	Rp3/4	3,8	RAL 3001
N 25	25	1,0	400	252	90	Rp3/4	5,0	RAL 3001
N 35	35	1,0	440	290	110	Rp3/4	7,0	RAL 3001
N 50	50	1,0	500	318	145	Rp3/4	10,5	RAL 3001
N 80	80	1,0	600	368	165	Rp3/4	14,5	RAL 3001
N 100	100	1,0	600	433	184	Rp3/4	16,0	RAL 3001
N 140	140	1,0	600	572	193	Rp3/4	20,0	RAL 3001

- 1... connection for expansion pipe (installation in system return, max. long-term temperature at the connection point 70 °C)
- 2... gas pressure valve with sealing cap and valve protection cap
- 3... wall mount (at N 4 - N 100 executed as single-point mount, at N 140 executed as four-point bracket for wall mount or installation on the floor)

elko-flex eder NP series

Safety expansion vessel, specifically designed for sealed heating systems with buffer tanks, acc. to EN 12828. Constructed with a flanged exchangeable diaphragm to accommodate the expansion volume, gas filling with gas pressure valve and connection for a maintenance unit. Designed as standing vessel with well-designed and functional stand feet.

- Tested in accordance with PED 2014/68/EU
- max. safety temperature of the system without/with cooling vessel: 90/110 °C
- max. temp. at the connection point: 70 °C
- max. operating pressure: 3 bar
- permissible medium: water resp. water/glycol mixture (other plant media can be checked on request)

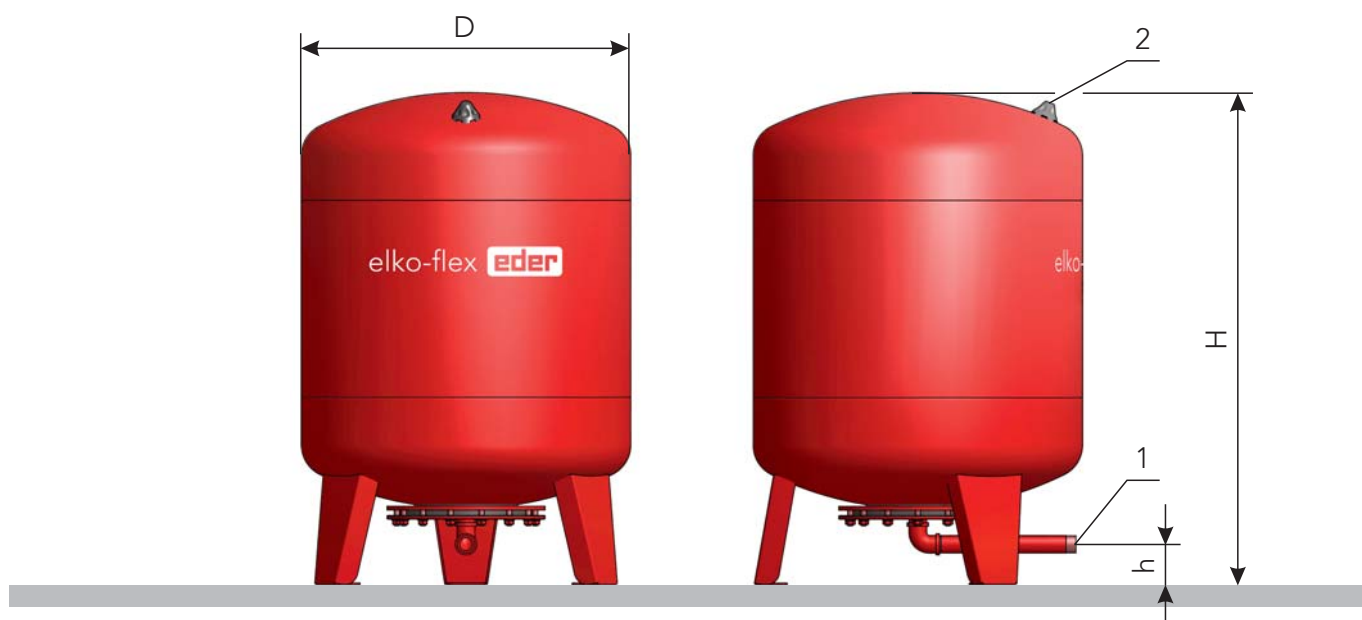

NP 115 - NP 230

type	nom. content [Liter]	standard gas pressure [bar]	D [mm]	H [mm]	h [mm]	connection ["]	weight [kg]	colour
NP 115	115	1,0	500	750	60	R3/4	30,0	RAL 3001
NP 230	230	1,0	600	1075	60	R3/4	46,0	RAL 3001

- 1... connection for expansion pipe (installation in system return, max. long-term temperature at the connection point 70 °C)
- 2... gas pressure valve with sealing cap and valve protection cap

elko-flex eder SG series

Safety expansion vessel for sealed heating, climatic and cold water systems acc. to EN 12828. Constructed with a flanged exchangeable diaphragm to accommodate the expansion volume, gas filling with gas pressure valve and connection for a maintenance unit. Designed as standing vessel with well-designed and functional stand feet.

- Tested in accordance with PED 2014/68/EU
- max. safety temperature of the system without/with cooling vessel: 90/110 °C
- max. temp. at the connection point: 70 °C
- max. operating pressure: 3 bar
- permissible medium: water resp. water/glycol mixture (other plant media can be checked on request)

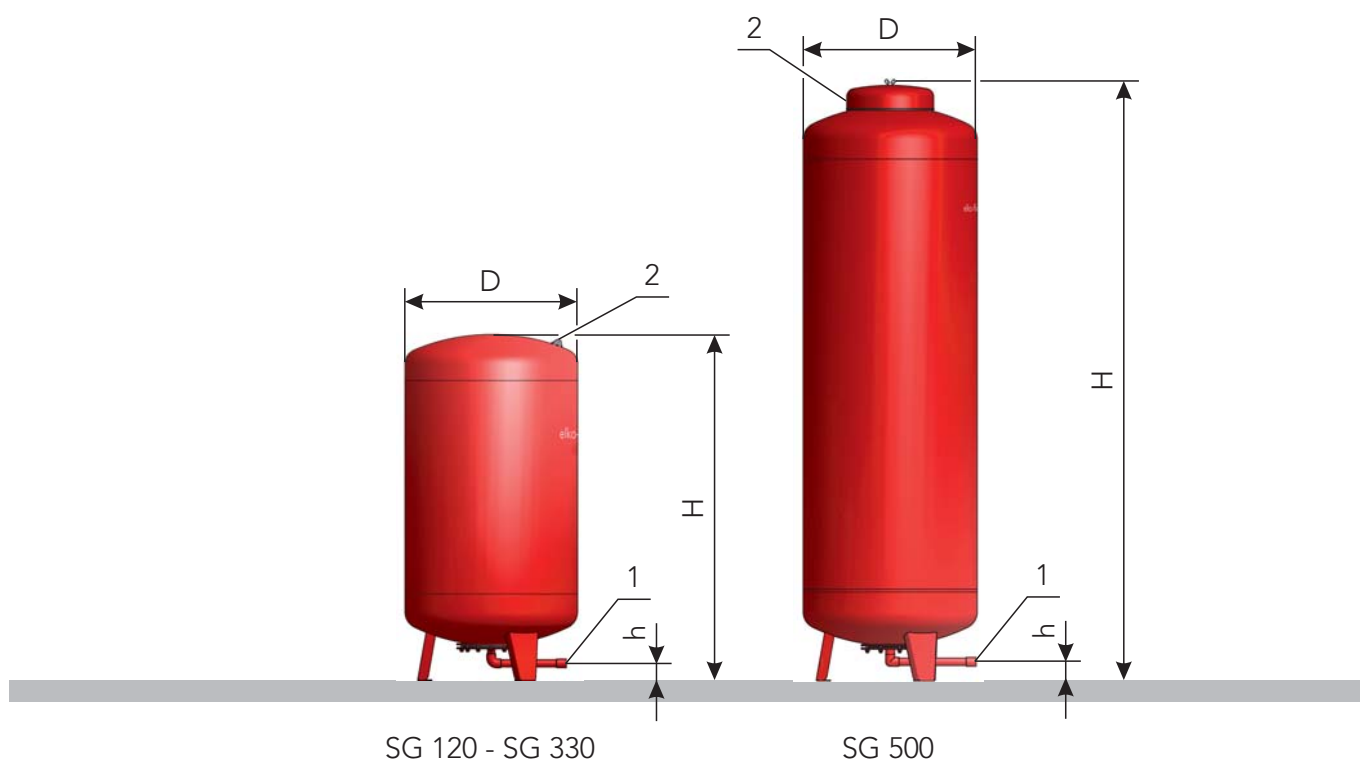

type	nom. content [Liter]	standard gas pressure [bar]	D [mm]	H [mm]	h [mm]	connection ["]	weight [kg]	colour
SG 120	120	1,3	500	790	60	Rp3/4	30,0	RAL 3001
SG 180	180	1,3	500	1080	60	Rp3/4	40,0	RAL 3001
SG 250	250	1,3	600	1090	60	Rp3/4	47,0	RAL 3001
SG 330	330	1,3	600	1340	60	Rp3/4	58,0	RAL 3001
SG 500	500	1,3	600	2090	60	Rp3/4	85,0	RAL 3001

- 1... connection for expansion pipe (installation in system return, max. long-term temperature at the connection point 70 °C)
- 2... gas pressure valve with sealing cap and valve protection cap

elko-flex eder C series

Safety expansion vessel for sealed heating, climatic and cold water systems acc. to EN 12828. Constructed with a flanged exchangeable diaphragm to accommodate the expansion volume, gas filling with gas pressure valve and connection for a maintenance unit (in scope of delivery). Compact design as standing vessel with well-designed and functional stand feet.

- Tested in accordance with PED 2014/68/EU
- max. safety temperature of the system without/with cooling vessel: 90/110 °C
- max. temp. at the connection point: 70 °C
- max. operating pressure: 3 bar
- permissible medium: water resp. water/glycol mixture (other plant media can be checked on request)

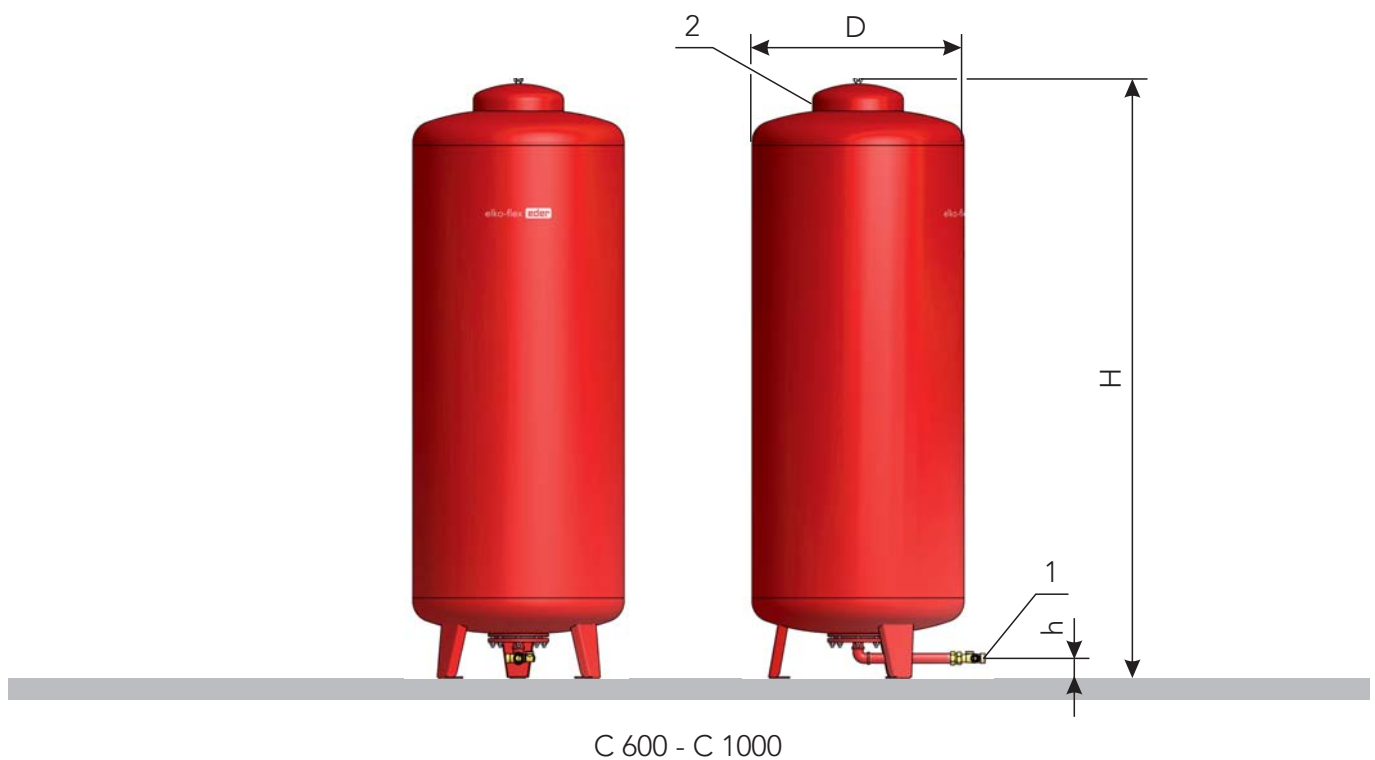

type	nom. content [Liter]	standard gas pressure [bar]	D [mm]	H [mm]	h [mm]	connection ["]	weight [kg]	colour
C 600	600	1,3	700	1990	65	R1	95,0	RAL 3001
C 800	800	1,3	800	2000	50	R1	104,0	RAL 3001
C 1000	1000	1,3	900	2050	75	R1	135,0	RAL 3001

- 1... connection for expansion pipe (installation in system return, max. long-term temperature at the connection point 70 °C)
- 2... gas pressure valve with sealing cap and valve protection cap

elko-flex eder CV series

Safety expansion vessel for sealed heating, climatic and cold water systems acc. to EN 12828. Constructed with a flanged exchangeable diaphragm to accommodate the expansion volume, gas filling with gas pressure valve and connection for a maintenance unit (in scope of delivery). Compact and reinforced design as standing vessel with well-designed and functional stand feet.

- Tested in accordance with PED 2014/68/EU
- max. safety temperature of the system without/with cooling vessel: 90/110 °C
- max. temp. at the connection point: 70 °C
- max. operating pressure: 5 bar
- permissible medium: water resp. water/glycol mixture (other plant media can be checked on request)

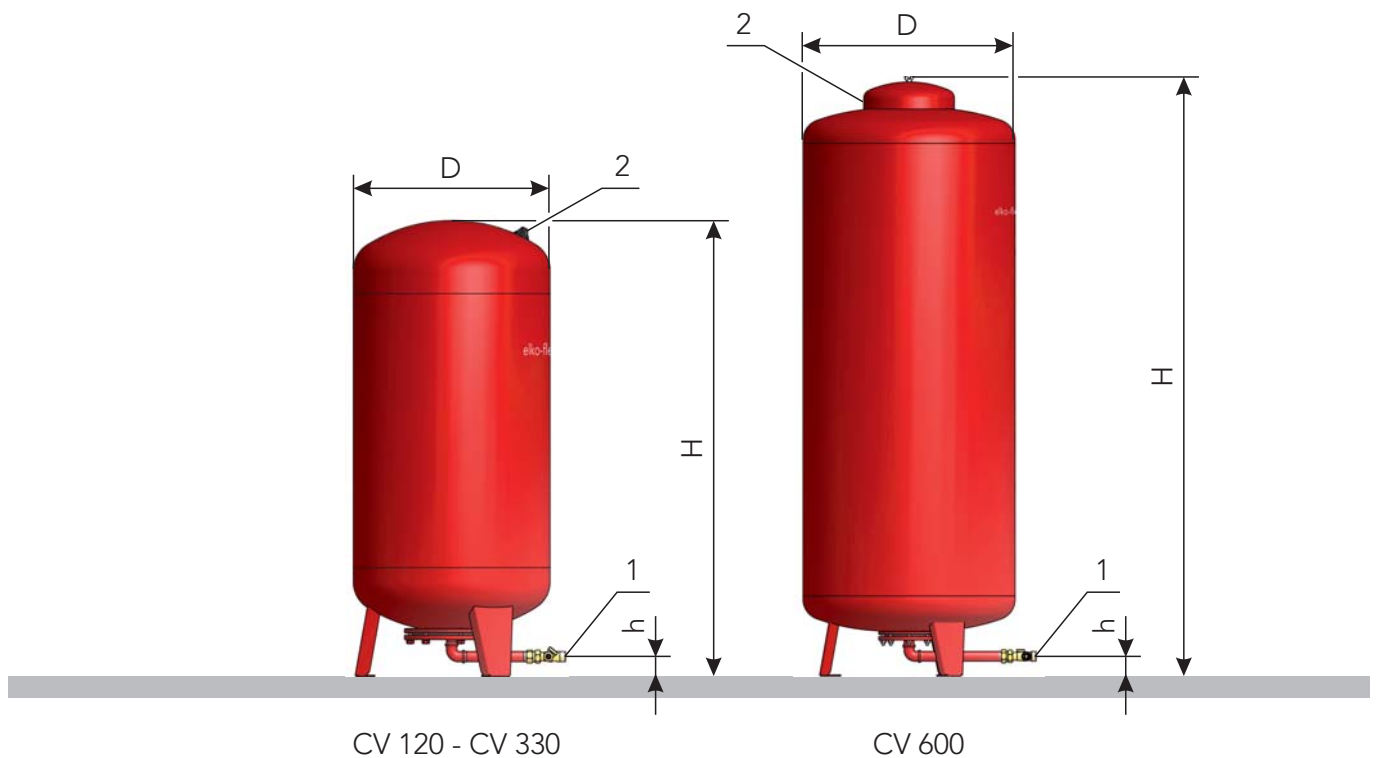

type	nom. content [Liter]	standard gas pressure [bar]	D [mm]	H [mm]	h [mm]	connection ["]	weight [kg]	colour
CV 120	120	3,3	500	860	50	R3/4	40,0	RAL 3001
CV 180	180	3,3	500	1185	50	R3/4	55,0	RAL 3001
CV 250	250	3,3	600	1195	60	R3/4	73,0	RAL 3001
CV 330	330	3,3	600	1395	60	R3/4	84,0	RAL 3001
CV 600	600	3,3	700	1990	50	R1	161,0	RAL 3001

- 1... connection for expansion pipe (installation in system return, max. long-term temperature at the connection point 70 °C)
- 2... gas pressure valve with sealing cap and valve protection cap

4.2 Universal vessels for heating, climatic and cold water systems

elko-flex eder U_-6 series

Universal safety expansion vessel for sealed heating, climatic and cold water systems acc. to EN 12828, refrigeration systems, solar systems and cold water sanitary systems*. Non-flow-through construction with a flanged exchangeable diaphragm (resistant to common antifreeze fluids, the flange is made of stainless steel) to accommodate the expansion volume, gas filling with gas pressure valve and connection for a maintenance unit. Designed for wall mount installation incl. functional mounting bracket (18 - 50 l) resp. as standing vessel with well-designed and functional stand feet (90 - 300 l).

- Tested in accordance with PED 2014/68/EU
- max. safety temperature of the system without/with cooling vessel: 90/110 °C
- max. temp. at the connection point: 70 °C
- max. operating pressure: 6 bar
- permissible medium: water resp. water/glycol mixture (other plant media can be checked on request)

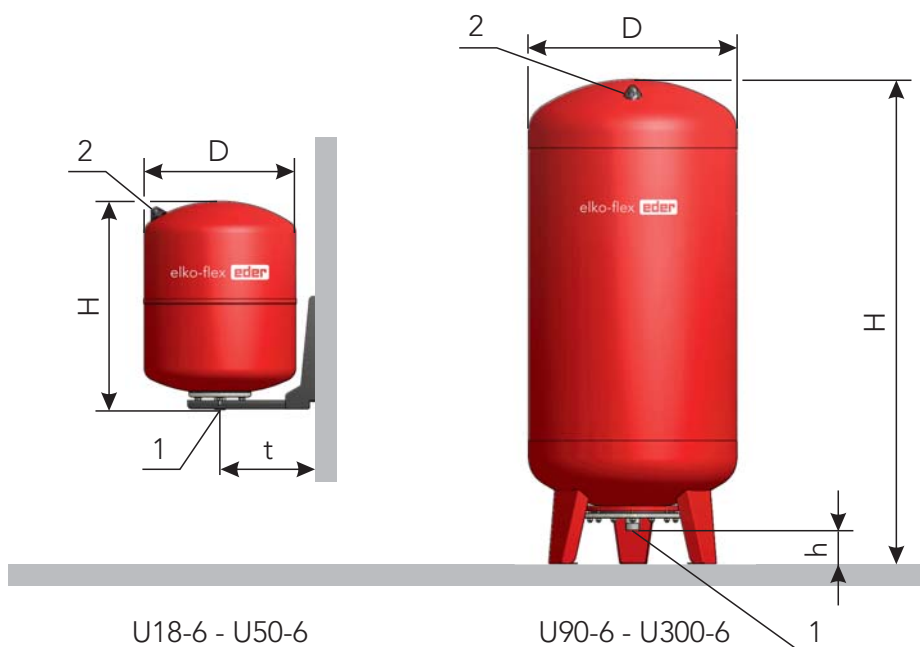

* Depending on the intended use of the universal vessel, you will find the corresponding details in the respective chapter of this document.

type	nom. content [Liter]	standard gas pressure [bar]	D [mm]	H [mm]	t / h [mm]	connection ["]	weight [kg]	colour
U18-6	18	3,5	300	365	230	R3/4	7,9	RAL 3001
U25-6	25	3,5	360	400	230	R3/4	9,8	RAL 3001
U35-6	35	3,5	360	500	230	R3/4	10,5	RAL 3001
U50-6	50	3,5	360	580	230	R3/4	14,8	RAL 3001
U90-6	90	3,5	440	820	85	R1	31,3	RAL 3001
U120-6	120	3,5	500	835	85	R1	40,5	RAL 3001
U200-6	200	3,5	500	1260	85	R1	56,0	RAL 3001
U300-6	300	3,5	600	1400	85	R1	81,4	RAL 3001

- 1... connection for expansion pipe (installation in system return, max. long-term temperature at the connection point 70 °C)
- 2... gas pressure valve with sealing cap and valve protection cap

elko-flex eder U_-10 series

Universal safety expansion vessel for sealed heating, climatic and cold water systems acc. to EN 12828, refrigeration systems, solar systems and cold water sanitary systems. Non-flow-through construction with a flanged exchangeable diaphragm (resistant to common antifreeze fluids, the flange is made of stainless steel) to accommodate the expansion volume, gas filling with gas pressure valve and connection for a maintenance unit. Designed for wall mount installation incl. functional mounting bracket (15 - 60 l) resp. as standing vessel with well-designed and functional stand feet (120 - 300 l).

- Tested in accordance with PED 2014/68/EU
- max. safety temperature of the system without/with cooling vessel: 90/110 °C
- max. temp. at the connection point: 70 °C
- max. operating pressure: 10 bar
- permissible medium: water resp. water/glycol mixture (other plant media can be checked on request)

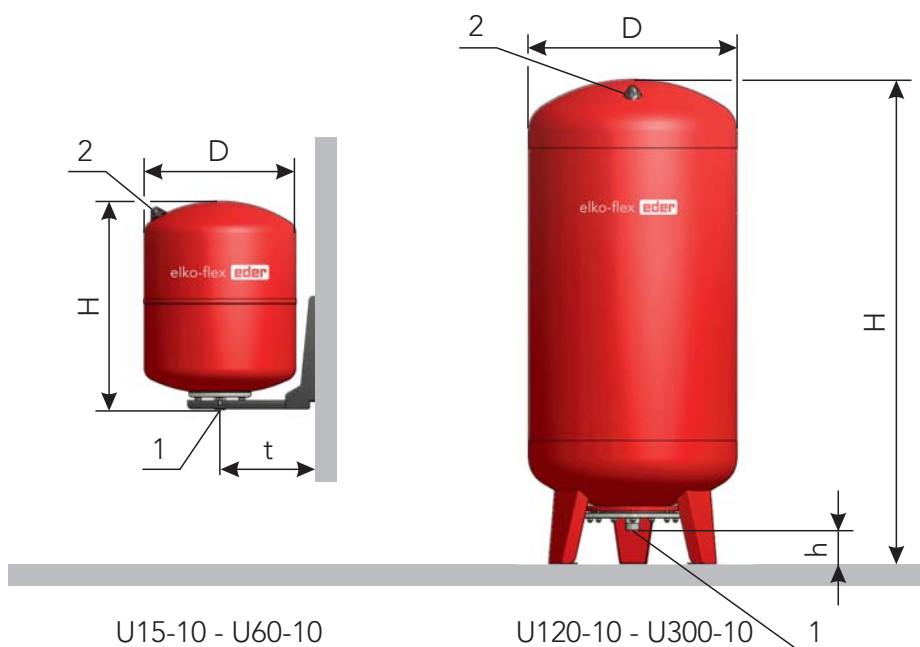

* Depending on the intended use of the universal vessel, you will find the corresponding details in the respective chapter of this document.

type	nom. content [Liter]	standard gas pressure [bar]	D [mm]	H [mm]	t / h [mm]	connection ["]	weight [kg]	colour
U15-10	15	3,5	300	310	230	R3/4	6,1	RAL 3001
U20-10	20	3,5	300	360	230	R3/4	6,7	RAL 3001
U30-10	30	3,5	360	420	230	R3/4	9,6	RAL 3001
U60-10	60	3,5	360	695	230	R3/4	15,8	RAL 3001
U120-10	120	3,5	500	870	75	R1	30,0	RAL 3001
U180-10	180	3,5	500	1180	80	R1	55,0	RAL 3001
U240-10	240	3,5	600	1195	80	R1	73,0	RAL 3001
U300-10	300	3,5	600	1400	80	R1	84,0	RAL 3001

- 1... connection for expansion pipe (installation in system return, max. long-term temperature at the connection point 70 °C)
- 2... gas pressure valve with sealing cap and valve protection cap

4.3 Expansion vessels for warm water sanitary systems

elko-san eder San D series

Safety expansion vessel for warm water sanitary systems. Constructed with a flanged exchangeable diaphragm (made of food-safe and tasteless material, the flange is made of stainless steel) to accommodate the expansion volume (caused by heating-up of the water boiler), gas filling with gas pressure valve and - for flow-through - connections for two maintenance units. Designed for wall mount installation incl. functional mounting bracket (20 - 60 l) resp. as standing vessel with well-designed and functional stand feet (90 - 300 l).

- Tested in accordance with PED 2014/68/EU
- max. safety temperature of the system without/with cooling vessel: 90/110 °C
- max. temp. at the connection point: 70 °C
- max. operating pressure: 10 bar
- permissible medium: intended for water but also permissible for water/glycol mixture (other plant media can be checked on request)

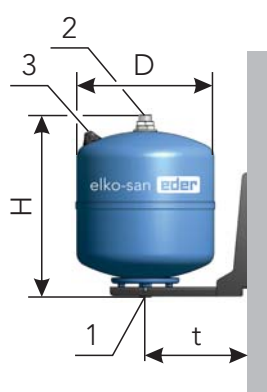

San 20 D - San 60 D

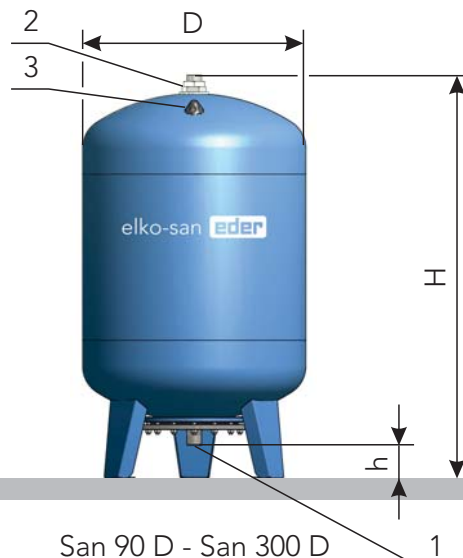

San 90 D - San 300 D

type	nom. content [Liter]	standard gas pressure [bar]	D [mm]	H [mm]	t / h [mm]	connection ["]	weight [kg]	colour
San 20 D	20	3,5	300	410	230	R3/4	6,9	RAL 5015
San 30 D	30	3,5	360	445	230	R3/4	11,0	RAL 5015
San 60 D	60	3,5	360	715	230	R3/4	16,4	RAL 5015
San 90 D	90	3,5	440	900	90	R1	32,6	RAL 5015
San 120 D	120	3,5	500	900	80	R1	35,0	RAL 5015
San 180 D	180	3,5	500	1220	80	R1	60,0	RAL 5015
San 240 D	240	3,5	600	1235	80	R1	78,0	RAL 5015
San 300 D	300	3,5	600	1440	80	R1	89,0	RAL 5015

- 1 ... connection FROM cold water
 2 ... connection TO cold water
 2 ... gas pressure valve with sealing cap and valve protection cap

4.4 Expansion vessels for cold water sanitary systems

elko-san eder San series

Safety expansion vessel for cold water sanitary systems to absorb pressure surges or as water pressure tanks. Constructed with a flanged exchangeable diaphragm (made of food-safe and tasteless material, the flange is made of stainless steel), gas filling with gas pressure valve and connection for a maintenance unit. Designed for wall mount installation incl. functional mounting bracket (15 - 60 l) resp. as standing vessel with well-designed and functional stand feet (120 - 300 l).

- Tested in accordance with PED 2014/68/EU
- max. temp. at the connection point: 70 °C
- max. operating pressure: 10 bar
- permissible medium: intended for water but also permissible for water/glycol mixture (other plant media can be checked on request)

Caution: elko-san eder San series expansion vessels are not intended as shock absorbers in their proper sense!

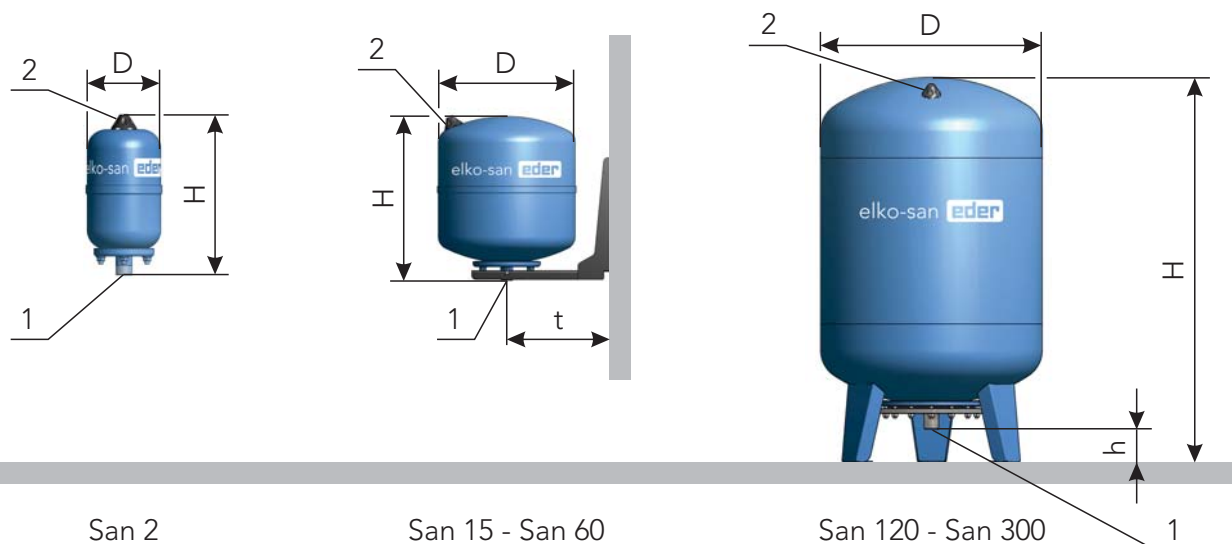

type	nom. content [Liter]	standard gas pressure [bar]	D [mm]	H [mm]	t / h [mm]	connection ["]	weight [kg]	colour
San 2	2	3,5	120	260	-	R3/4	2,3	RAL 5015
San 15	15	3,5	300	310	230	R3/4	6,1	RAL 5015
San 20	20	3,5	300	360	230	R3/4	6,7	RAL 5015
San 30	30	3,5	360	420	230	R3/4	9,6	RAL 5015
San 60	60	3,5	360	695	230	R3/4	15,8	RAL 5015
San 120	120	3,5	500	870	75	R1	30,0	RAL 5015
San 180	180	3,5	500	1180	80	R1	55,0	RAL 5015
San 240	240	3,5	600	1195	80	R1	73,0	RAL 5015
San 300	300	3,5	600	1400	80	R1	84,0	RAL 5015

- 1... connection for expansion pipe (max. long-term temperature at the connection point 70 °C)
2... gas pressure valve with sealing cap and valve protection cap

4.5 Safety expansion vessel for refrigeration systems (cold water systems, chillers)

elko-flex eder Cool series

Safety expansion vessel for refrigeration systems. Constructed with a flanged exchangeable diaphragm (resistant to common antifreeze fluids, the flange is made of stainless steel) to accommodate the expansion volume, gas filling with gas pressure valve and connection for a maintenance unit. Designed for wall mount installation incl. functional mounting bracket.

- Tested in accordance with PED 2014/68/EU
- max. temp. at the connection point: 70 °C
- min. temp. at the connection point: -10 °C
- max. operating pressure: 6 bar
- permissible medium: intended for water but also permissible for water/glycol mixture (other plant media can be checked on request)

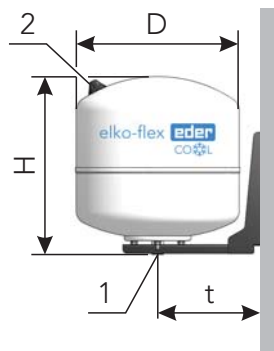

Cool 18 - Cool 50

type	nom. content [Liter]	standard gas pressure [bar]	D [mm]	H [mm]	t [mm]	connection ["]	weight [kg]	colour
Cool 18	18	3,5	300	365	230	R3/4	7,9	RAL 7035
Cool 25	25	3,5	360	400	230	R3/4	9,8	RAL 7035
Cool 35	35	3,5	360	500	230	R3/4	10,5	RAL 7035
Cool 50	50	3,5	360	580	230	R3/4	14,8	RAL 7035

- 1 ... connection for expansion pipe to the cold water system
 2 ... gas pressure valve with sealing cap and valve protection cap

4.6 Safety expansion vessel for solar system

elko-flex eder Solar series

Safety expansion vessel for solar systems. Constructed with a flanged exchangeable diaphragm (resistant to common antifreeze fluids, the flange is made of stainless steel) to accommodate the expansion volume, gas filling with gas pressure valve and connection for a maintenance unit. Designed for wall mount installation incl. functional mounting bracket (18 - 50 l) resp. as standing vessel with well-designed and functional stand feet (90 - 300 l).

- Tested in accordance with PED 2014/68/EU
- max. temp. at the connection point: 70 °C
- max. operating pressure: 6 bar
- permissible medium: intended for water but also permissible for water/glycol mixture (other plant media can be checked on request)

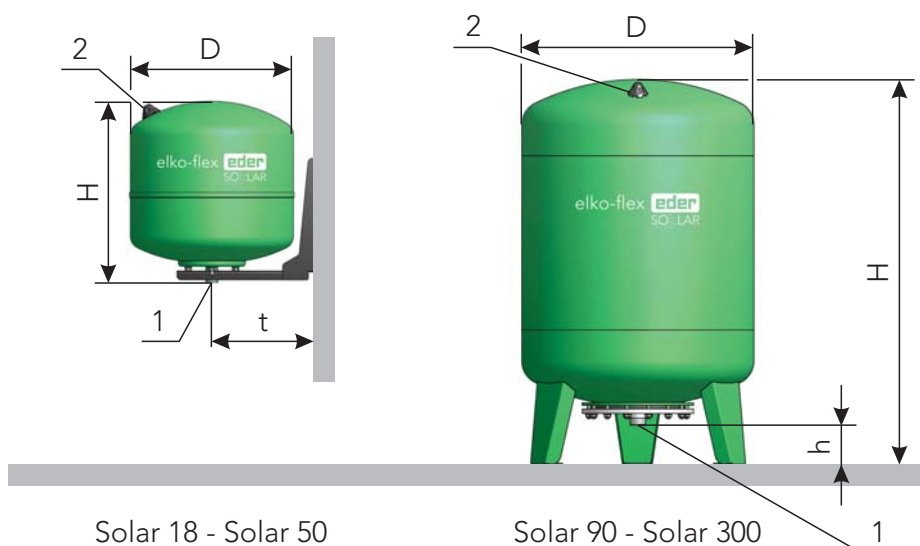

Note: The U_-6 series can be used as an alternative to the Solar series.

For solar systems up to max. 10 bar the U_-10 series can be installed.

type	nom. content [Liter]	standard gas pressure [bar]	D [mm]	H [mm]	t / h [mm]	connection ["]	weight [kg]	colour
Solar 18	18	3,5	300	365	230	R3/4	7,9	RAL 6010
Solar 25	25	3,5	360	400	230	R3/4	9,8	RAL 6010
Solar 35	35	3,5	360	500	230	R3/4	10,5	RAL 6010
Solar 50	50	3,5	360	580	230	R3/4	14,8	RAL 6010
Solar 90	90	3,5	440	820	85	R1	31,3	RAL 6010
Solar 120	120	3,5	500	835	85	R1	40,5	RAL 6010
Solar 200	200	3,5	500	1260	85	R1	56,0	RAL 6010
Solar 300	300	3,5	600	1400	85	R1	81,4	RAL 6010

- 1... connection for expansion pipe to the solar system
2... gas pressure valve with sealing cap and valve protection cap

5. Accessory

5.1 elko-flex eder maintenance unit

An elko-flex eder maintenance unit is a connection accessory for diaphragm expansion vessels for approved integration into a system with all necessary maintenance functions.

To ensure a proper function of the vessel and the whole system for a long term expansion vessels with a constant primary pressure have to be checked regularly (recommended every year, but at least every 2 years). Though the gas pressure in the vessel in the water-sided, pressureless condition is proved and corrected if necessary.

The vessel has to be separated from the system by an armature and to be emptied.

Excerpt of standard EN 12828: During operation the connection between the pressurization system and the heat generator has to be permanently open. For maintenance it is recommended to build in a valve between the pressurization system and the heat generator. The valve has to be secured against unintended closing, equipped with a drainage valve and used as a shut-off device.

Excerpt of standard ÖNORM H 5151-1: Between expansion- or pressurization system and heat generator maintenance and exchange of expansion- or pressurization devices has to be enabled by suitable equipment.

Technical data:

max. operating pressure: 10bar

max. operating temperature: 95 °C

type	connection to system ["]	connection to vessel ["]	length [mm]
3/4" a/a	R3/4	R3/4	104
3/4" a/i	R3/4	Rp3/4	87
1" a/i	R1	Rp1	101

type overview elko-flex eder maintenance unit:

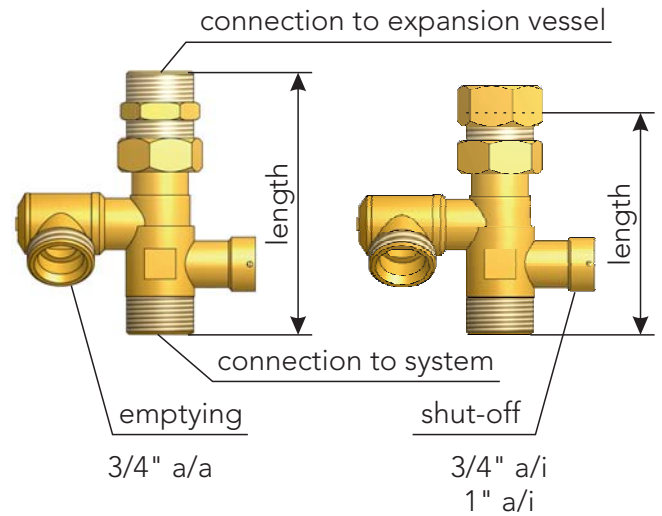

5.2 elko-mat eder EV cooling vessel

EV cooling vessels are intended for cooling the expansion volume before it enters the safety expansion vessel. Therefore the safety expansion vessel is protected against too high temperatures.

EV cooling vessels must be provided if the temperature at the connection point exceeds the max. allowed temperature of 70 °C

max. operating temperature (=safety temperature) of the system: 110 °C

Special versions of EV cooling vessels for operating temperatures higher than 110 °C can be delivered on request.

example: elko-flex eder safety expansion vessel with EV cooling vessel:

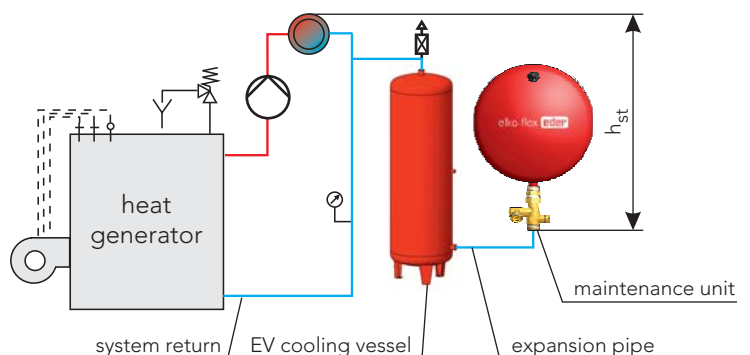

5.3 elko-flex eder SV safety valve elko-mat eder SV safety valve

To ensure that the maximum operating pressure is not exceeded, each heat generator of a heating system has to be assured by a safety valve.

The safety valve must be installed as close as possible to the heat generator - as long as the heat generator is not equipped with a safety valve ex works.

Safety valves shall:

- have a minimum dimension of DN15
- open at a pressure which does not exceed the maximum operating pressure of the system. Further it must avoid an exceeding of more than 10 % of the max. operating pressure. In case of a max. operating pressure of not more than 3 bar an exceeding of 0,5 bar is admissible.
- be designed in a way that the pressure loss does not exceed 3 % in the inlet pipe and 10 % in the outlet, compared to the set pressure of the safety valve.
- be installed at an easy accessible position and as close as possible to the flow pipe of the heat generator. Between the heat generator and the safety valve no shut-off device must be installed!

Safety valves should be dimensioned and set so that the operating overpressure in normal heating operation resp. in case of failure cannot be exceeded by more than 10 %. When the operating overpressure is below 3 bar, a pressure in excess of maximal 0,3 bar is admissible. The safety valves should close when the pressure drops within a range of 10 % of the response overpressure. A pressure reduction of 0,3 bar is admissible with response overpressures below 3 bar.

4.3.1 Selection of the safety valve:

To select a suitable safety valve the following technical specifications are necessary:

- nominal power of the heat generator
- set pressure of the safety valve p_{SV}

static height h_{st} of the heating system [mWs]	min. set pressure p_{SV} [bar]
$h_{st} \leq 10$	3,0
$h_{st} > 10$	$p_{st} + 2,0$

The selection of the safety valves based on their relief capacity depends on their type-examination.

The relief capacities of elko-flex eder SV resp. elko-mat eder SV safety valves are summarized in table 7.

table 7:
Relief capacities of elko-flex eder SV / elko-mat eder SV safety valves

set pressure p_{SV} [bar]	relief capacity of the safety valve [kW] in reference to the inlet dimension and the set pressure p_{SV}					
	DN15 (1/2")	DN20 (3/4")	DN25 (1")	DN32 (5/4")	DN40 (6/4")	DN50 (2")
3	50	100	200	350	600	900
4	undeliverable	undeliverable	200	350	600	900
5	undeliverable	undeliverable	200	350	600	900
6	75	150	250	350	600	900
8	undeliverable	undeliverable	250	350	600	900
10	undeliverable	undeliverable	250	350	600	900

BETTER HEATING. SAFE BET.



www.eder-heizung.at

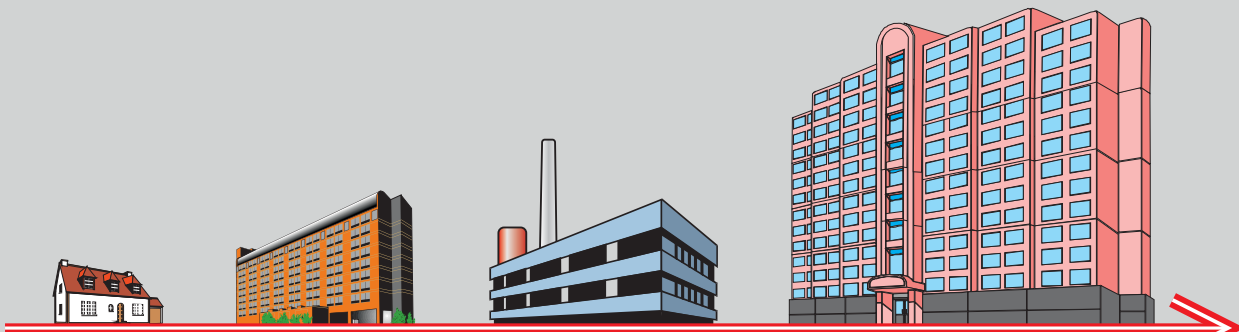

elko-flex eder



plant complexity
(generating capacity,
static height,
total content,
working pressure)

elko-mat eder picocontrol PCK



elko-mat eder multicontrol MCK



elko-mat eder multicontrol MCM



elko-mat eder topcontrol TCM



EDER SPIROTECH GMBH

A-9909 Leisach 52

Tel.: +43 (0) 4852 644 77

Fax: +43 (0) 4852 644 77-20

E-Mail: info@eder-heizung.at

branch A-5733 Bramberg | Weyerstraße 350 | Tel.: +43 (0) 6566 7366

branch A-1230 Vienna | Gorskistraße 15 | Tel.: +43 (0) 1 985 37 30

